



 **RAPHAEL**

Product Catalog

# RAF Series for Waterworks

Diaphragm Control Valve



## RAF PURPOSE HYDRAULIC VALVES

### Technical Information

RAF 31-33	Electric Control Valve	6
RAF 10	Float Level Control Valve	8
RAF 13	Bi-level Float Control Valve	10
RAF 1031	Electric Float Control Valve	12
RAF 60/62	2-Way Pressure Reducing Control Valve	14
RAF 63B	3-Way Pressure Reducing Control Valve	16
RAF 68/682	2-Way Pressure Reducing/Sustaining Control Valve	18
RAF 683B	3-Way Pressure Reducing/Sustaining Control Valve	20
RAF 80/82	2-Way Pressure Sustaining/Relief Control Valve	22
RAF 80Q	Quick Pressure Relief Valve	24
RAF 83B	3-Way Pressure Sustaining/Relief Control Valve	26
RAF 70	Flow Rate Control Valve	28
RAF 20	Pump Protection Control Valve	30
RAF 40/43	Altitude Control Valve	32
RAF 88	Surge Anticipating Control Valve	34
RAF 90	Anti-Burst Control Valve	36

# RAF SERIES HYDRAULIC VALVES

## RAF IRRIGATION

RAF valves are used for general water supply and irrigation. The RAF valves are made of only three parts; each one is made of durable materials. The inner flow passages are streamlined and coated with low-friction materials. This provides quiet flow in both directions, low head loss and minimal wear. Valves operate with a patented reinforced diaphragm, which eliminates the need for a retaining metal spring. The special elastic design enables gradual and precise opening or closing of the valve. By eliminating the metal spring, the RAF is virtually maintenance free.

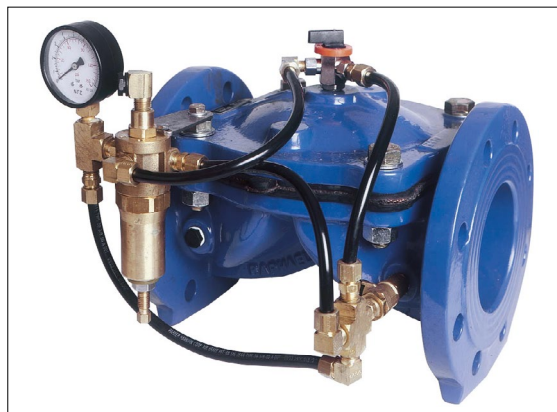

### APPLICATIONS

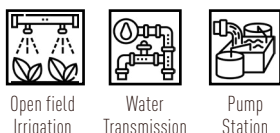

Open field Irrigation    Water Transmission    Pump Station

### TECHNICAL DATA

**Nominal Diameter (DN):** from 25 to 400 mm (1.5" to 16")  
**Fluid:** drinking water, or filtered water  
**Nominal Pressure (PN):** 16 bar  
**Working temperature:** up to 70°C  
**Body material:** cast iron  
**Pipe connection:** flanged, threaded or grooved

### OPTIONAL MATERIALS

**Body:**  
 - Ductile Iron  
 - Bronze  
 - Stainless Steel  
**Cover:**  
 - Ductile Iron  
 - Bronze  
 - Stainless Steel  
**Diaphragm zinc:**  
 - EPDM  
 - Nitrile  
**Nuts:** Stainless Steel  
**Washer:** Stainless Steel  
**Bolts:** Stainless Steel  
**Coating:** Epoxy Powder Internal - Enamel

### CHARACTERISTICS

└ **Unique concept of diaphragm hydraulic control valve** consisting of three basic parts: Body, cover and diaphragm

└ The «no-spring» diaphragm valve **ensures even distribution of pressure** on the sealing area, **prevents diaphragm deformation** and **provides longer service life**. The valve contains a minimum number of moving parts and requires practically no maintenance

└ The patented rib-style diaphragm has several advantages. Valve opening and closing is gradual and **eliminates risk of water hammer, vibration and noise**

- └ It provides **accurate and perfect pressure regulation** at low flow-rates
- └ Full valve opening is obtained at a very low minimum opening pressure



### FEATURES AND BENEFITS

**Maintenance Free Valve** by having no spring inside and a simple and reliable three parts valve: cover, patented diaphragm and body.

**Stability and accurate regulation even at low flow rate** based on the patented diaphragm integrated ribs to replace spring. This allow gradual opening and closing with no risk of noise, vibration or water hammer.

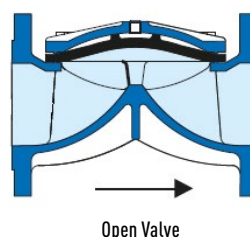
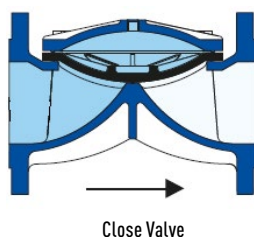

## PART LIST OF MAIN VALVE STANDARD FEATURE:

Ref	Name	Material
1	Body	Ductil Iron Epoxy polyester coating
2	Diaphragm	Natural Rubber
3	Cover	Ductile Iron Epoxy polyester coating
4/5/6	Fixing elements Coating	Plated Steel Rilsan

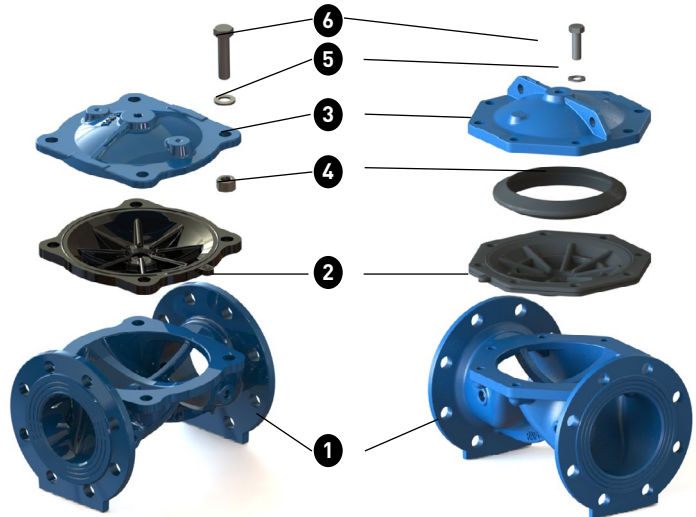

## RECOMMENDED WORKING CONDITIONS RANGE

DN		Inlet Pressure (Bar)		*Kv factor (Fully opened valve)		Control Chamber Volume	
mm	inch	Min.	Max.	RAF	RAF-A	Liter	Gallon
40	1.5	0.8	16	40	-	0.06	0.016
50	2	0.7	16	70	62	0.08	0.021
65	2.5	0.7	16	100	90	0.16	0.042
80-65-80	3-2.5-3	0.7	16	130	100	0.16	0.042
80	3	0.7	16	170	155	0.3	0.079
100-80-100	4-3-4	0.7	16	170	155	0.3	0.079
100	4	0.4	16	290	200	0.7	0.185
125-100-125	5-4-5	0.4	16	290	200	0.7	0.185
150-100-150	6-4-6	0.4	16	300	220	0.7	0.185
150	6	0.4	16	490	470	1.5	0.396
200	8	0.4	16	790	-	3.5	0.924
250	10	0.3	16	1400	-	7.6	20.006
300	12	0.3	16	1800	-	7.6	20.006
350-300-350	14-12-14	0.3	16	1450	-	7.6	20.006
350-400-350	14-16-14	0.3	16	1850	-	25	6.6
400	16	0.3	16	1950	-	25	6.6

Kv=Valve flow coefficient [m<sup>3</sup>/h]; [bar]

Q=Flow rate [m<sup>3</sup>/h]

ΔP=Head loss across the valve [bar]

Cv = Valve flow coefficient [(gpm); [psi]

Cv = 1.16 Kv

$$Q = Kv \cdot \sqrt{\Delta P}$$

# RAF & RAF ANGLE IN LINE

## DIMENSIONS

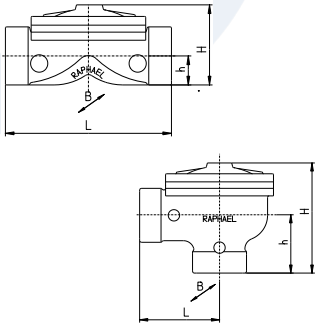

### Thread (#NP or #0)

DN		L (mm)		H (mm)		B (mm)		h (mm)		Weight (kg)	
mm	inch	RAF	RAFA	RAF	RAFA	RAF	RAFA	RAF	RAFA	RAF	RAFA
25	1	156		70		94		21		1.5	
40	1.5	159		80		96		29		2	
50	2	190	90	100	150	521	521	38	81	3.5	4.2
65	2.5	216	117	110	160	125	125	46	83	5	7
80D	3D	244	130	127	170	138	140	50	86	5.5	46
80	3	290	148	138	205	200	200	50	107	11	12
100	4	346	150	220	227	230	230	60	118	16.5	15.9

### Groove (#G)

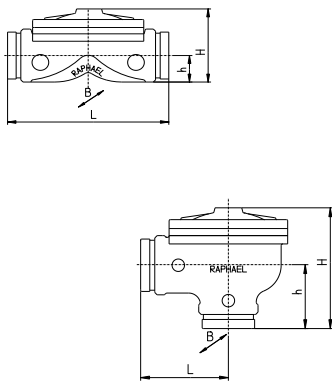

DN		L (mm)		H (mm)		B (mm)		h (mm)		Weight (kg)	
mm	inch	RAF	RAFA	RAF	RAFA	RAF	RAFA	RAF	RAFA	RAF	RAFA
25	1	156		70		94		21		1.4	
40	1.5	159		80		96		29		1.5	
50	2	190	90	100	150	521	521	38	81	3	4
65	2.5	216	117	110	160	125	125	46	83	4.7	5
80D	3D	244	130	127	170	138	140	50	86	5.2	5.5
80	3	290	148	138	205	200	200	50	107	10.8	11
100D	4D	285	157	180	220	200	200	74	114	17.5	11
100	4	346	150	220	227	230	230	60	118	18	15.6
150D	6D	330	206	260	315	230	300	96	150	19.8	28.3
150	6	412	206	241	317	300	300	88	150	33	32
200	8	470	225	350	400	354	354	125	170	51	45.5

### Flanged (#3)

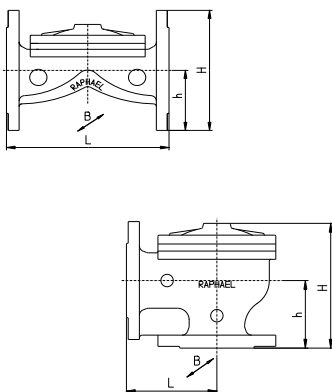

DN		L (mm)		H (mm)		B (mm)		h (mm)		Weight (kg)	
mm	inch	RAF	RAFA	RAF	RAFA	RAF	RAFA	RAF	RAFA	RAF	RAFA
50	2	190	112	159	159	165	561	76	77	7.9	8.1
65	2.5	216	122	173	160	185	185	80	83	9.3	11
80D	3D	216	130	192	215	200	200	92	115	11.4	11.65
80	3	283	154	200	210	200	200	100	115	17.5	19
100D	4D	283	155	222	225	222	220	111	110	20	19.5
100	4	305	177	220	230	230	230	99	113	26	26.5
125D	5D	305		243		250		120		29.5	
150D	6D	325		285		385		143		34.5	
150	6	406	218	295	315	300	300	142	148	46	48.7
200	8	470	225	383	400	354	354	160	170	67.5	62.5
250	10	635		430		464		197		111	
300	12	749		474		480		234		151	
350-300-350	14D	749		520		520		260		177	
350-400-350	14	766		648		616		267		257	
400	16	860		705		616		298.5		305	

Nominal diameter only, for full dimensions please refer to the Engineering department.

# RAF SERIES HYDRAULIC VALVES FOR WATERWORKS

## RAF 31-33 3-Way Electric Control Valve

RAF 31 and RAF 33 valves are activated by line pressure. The valves open or close by electric command through a selection of solenoid valves. The solenoid opens or closes the RAF as it is energized by an electric pulse.

The electric pulse that commands the valves is generated by a controller, timer, sensor or an electric control device.



### MARKETS



Open field  
Irrigation

Water  
Transmission

Pump  
Station

### TECHNICAL DATA

**Fluid:** raw water or filtered water

**Nominal Diameter (DN):**  
from 40 to 400 mm (1.5" to 16")

**Available connections:** Flanged,  
Threaded or Grooved

**Nominal Pressure (PN):** 16 bar

**Medium Temperature:**  
up to 70 °C

**Body material:** Ductile Iron

**Standard Controls:** Electric  
valve controls with Raphael's 3-W  
solenoid, activated by any voltage,  
reinforced plastic tubing and brass  
fittings.

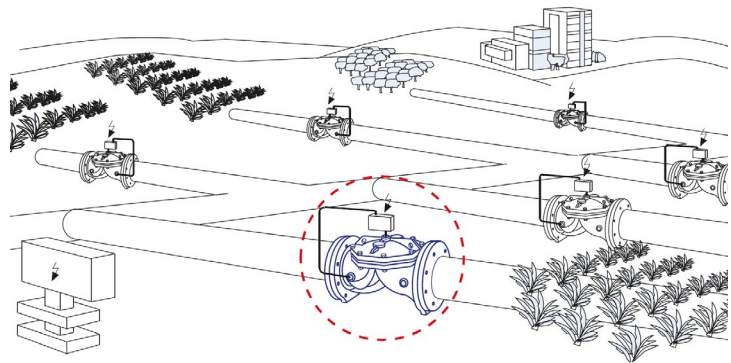

### TYPICAL APPLICATIONS

- Water supply systems with medium pressure rating
- Remote operation of hydraulic valve by an electric command
- Irrigation water distribution and field control

### RAF 31 - NORMALLY CLOSE MODE

By default of the normally closed RAF valve, the line pressure is connected to the RAF valve's control chamber above its diaphragm. Thus, the diaphragm is pressed downwards against the valve seat and the valve is closed. When the solenoid is energized by an electric pulse the line control chamber is disconnected from line pressure and drained through the solenoid's vent. The RAF's diaphragm is then forced upward by line pressure and fully opens.

### RAF 33 - NORMALLY OPEN MODE

By default of the normally open RAF valve, the RAF valve's control chamber is connected to the drain of the solenoid, the diaphragm is pressed upwards by line pressure and the valve fully opens. When the solenoid is energized by an electric pulse the pressure source connects to the control chamber of the valve. The line pressure pushes the diaphragm all the way downwards and the RAF closes.

The standard RAF 31/33 Electric control valve is a 3 way configured.

When the water from the control chamber cannot be drained to the atmosphere, from any reason, two way configurations are also available.

The valve can be then configured as a:

- \* 2 way Normally Close Electric Control valve (RAF 32)
- \* 2 way Normally Open Electric Control valve (RAF 30)

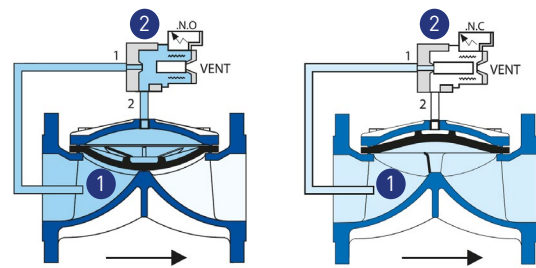

**RAF-33**  
3-W Electric Control Valve  
Normally Open (N.O.)

**RAF-31**  
3-W Electric Control Valve  
Normally Close (N.C.)

Ref	Name
1	Self-cleaning screen filter
2	3-W metal solenoid

## RECOMMENDED FLOW

Nominal Diameter		Flow Rate (m3/h)
mm	inch	Max.
40	1.5	25
50	2	45
65	2.5	60
80-65-80	3-2.5-3	70
80	3	90
100-80-100	4-3-4	90
100	4	150
125-100-125	5-4-5	150
150-100-150	6-4-6	150
150	6	320
200	8	550
250	10	950
300	12	1000
350	14	1300
400	16	1400

### FEATURES:

- RAF valve two-layered Epoxy-polyester coated
- Self-cleaning screen filter
- 3-W (N.O.) metal solenoid (RAF 31)
- 3-W (N.C.) metal solenoid (RAF 33)
- Reinforced plastic tubing
- Power source - 24V (AC) 50/60 Hz

### OPTIONAL FEATURES:

- Rilsan coating
- Large capacity external filter
- 2-W (N.C.) metal solenoid
- Copper and stainless steel tubing
- Power source - 110V, 220V (AC) & 9 V, 12V, 24V (DC)

Nominal diameter only, for full dimensions please refer to the Engineering department.

# RAF SERIES HYDRAULIC VALVES FOR WATERWORKS

## RAF 10 Float Level Control Valve

The **RAF 10** float level control valve is activated by line pressure in any situation that maximum water level should be maintained.

The **RAF 10** stays open as long as the water level in the reservoir is below the maximum preset level. As the water level rises and lifts the float, the valve gradually closes.

When the water level is low, the control chamber of the valve is drained through the vent, the valve opens and the reservoir is being filled.

**Max. Working pressure:** up to 5 bar



### MARKETS

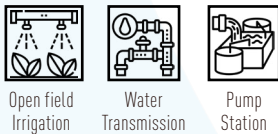

Open field  
Irrigation

Water  
Transmission

Pump  
Station

### TECHNICAL DATA

**Fluid:** raw water or filtered water

**Nominal Diameter (DN):**  
from 25 to 400 mm (1" to 16")

**Available connections:** Flanged,  
Threaded or Grooved

**Nominal Pressure (PN):** 16 bar

**Medium Temperature:**  
up to 70 °C

**Body material:** Ductile Iron

**Standard Controls:** Float level  
control valve controls with  
Raphael's 2-W float pilot.  
The pilot vent is opened or closed  
according to the float level.

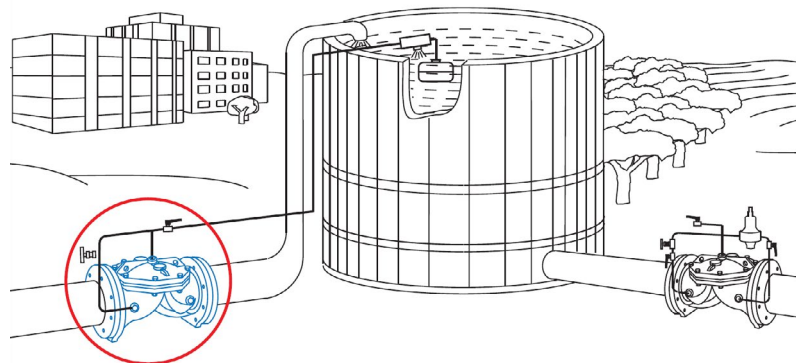

### TYPICAL APPLICATIONS

- Best fit in remotes sites
- Maintain a maximum preset water level in a reservoir or water tank in a simple and economic way.
- The RAF10 can be located above the water level
- Due to its simple design, it is maintenance free
- There is no need for energy other than line pressure.

### ADJUSTMENT

Adjust the needle valve (3) to allow a sufficient short closure time.  
Preset the pilot to the reservoir's desired maximum water level.



**AUTOMATIC OPERATION:**

When the water level is low, the lever drops due to the float weight, causing the vent to open and drain the control chamber of the RAF through the vent. The line pressure then pushes the diaphragm of the RAF upward, opening the RAF and filling up the reservoir. As the water level inside the tank rises, the float lever moves upward, mechanically closing the vent. Consequently, the RAF shuts due to the line pressure, pushing the diaphragm downward.

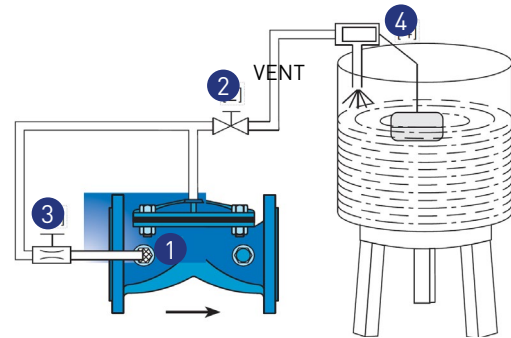

**RAF-10 2-W Float Level Control Valve**

Ref	Name
1	Self-cleaning screen filter
2	Cock valve
3	Needle valve
4	Float pilot assembly

**RECOMMENDED FLOW**

Nominal Diameter		Recommended Flow Rate [m <sup>3</sup> /h]	
mm	inch	Min.	Max.
25	1	3	22
40	1.5	3	25
50	2	5	45
65	2.5	5	70
80D	3D	5	70
80	3	5	90
100D	4D	5	90
100	4	10	150
125D	5D	10	150
150D	6D	10	150
150	6	15	320
200	8	40	550
250	10	80	950
300	12	100	1200
350	14	100	1200
400	16	100	1400

Nominal diameter only, for full dimensions please refer to the Engineering department.

**FEATURES**

- Basic RAF valve two-layered Epoxy-polyester coated
- Self-cleaning screen filter
- 2-W brass pilot P-10
- Brass float arm
- Stainless steel float
- 2-W selecting cock valve
- Needle valve
- Reinforced plastic tubing

**OPTIONAL FEATURES:**

- Rilsan coating
- Large capacity external filter
- Stainless steel pilot P-10
- Stainless Steel float arm
- Copper and stainless steel tubing

**PLEASE SPECIFY**

- Maximum operating pressure (closed valve)
- Minimum and maximum flow rate
- Maximum water level

# RAF SERIES HYDRAULIC VALVES FOR WATERWORKS

## RAF 13 Bi-Level Float Control Valve, 3-W Float Pilot

The RAF 13 is activated by line pressure and controls by a float pilot. The valve opens at a low preset water level and closes at a high preset water level. Therefore, there is no need for energy other than line pressure. The RAF 13 allows filling and draining of a reservoir or a water tank in a level range that can be easily changed. The RAF 13 stays in its last position (fully open or fully close) as long as the water level is in between minimum and maximum preset levels.

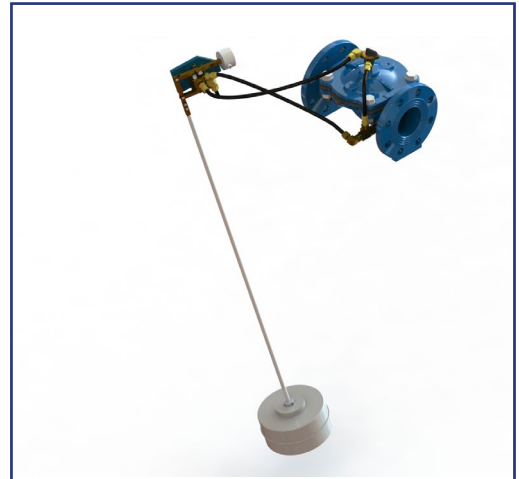

### MARKETS



Open field  
Irrigation



Water  
Transmission



Pump  
Station

### TECHNICAL DATA

**Fluid:** raw water or filtered water

**Nominal Diameter (DN):**  
from 40 to 400 mm (1.5" to 16")

**Available connections:** Flanged,  
Threaded or Grooved

**Nominal Pressure (PN):** 16 bar

**Medium Temperature:**  
up to 70 °C

**Body material:** Ductile Iron

**Standard Controls:** Foat level  
control valve controls with  
Raphael's 3-W float pilot.  
The vertical water level changes  
are conveyed to the float.

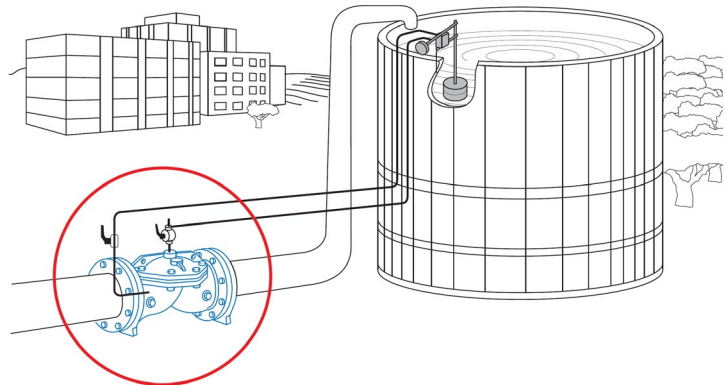

### TYPICAL APPLICATIONS

- Control filling of reservoirs and water tanks, in any situation that water level is controlled.
- Best fit where On/Off non-modulating valve operation is essential.
- Due to its simple design, it is virtually maintenance free.

### ADJUSTMENT

After installing the float pilot adjust the upper stopper to maximum required water level, fixing it to the rod.

Adjust in the same manner the lower stopper in the required minimum water level. Place the selecting Cock in auto position.

The float should not suffer fluctuations caused by the waves in the reservoir.

The float should be protected from the water inlet of the reservoir or water tank and as distant as possible.

**AUTOMATIC OPERATION:**

When the water level reduces the float slides down on the rod due to its weight. When it reaches the minimum preset level indicated by the lower stopper attached to the Pilot's rod, the pilot's vent port is connected to the control chamber of the RAF. The diaphragm of the RAF is forced upwards by line pressure, the RAF 13 opens and fills the reservoir.

When water level rises, the float slides upwards on the rod. The valve in this case will remain open until maximum preset level [upper stopper] is reached. At maximum, level the float forces upper stopper up. The control chamber is connected then through the pilot to pressure supply. The line pressure forces the RAF diaphragm downward and the valve closes, cutting water supply to the reservoir.

**MANUAL OPERATION:**

To open the valve overriding the float place the selecting cock in OPEN position.

To close the valve overriding the float place the selecting cock in CLOSE position.

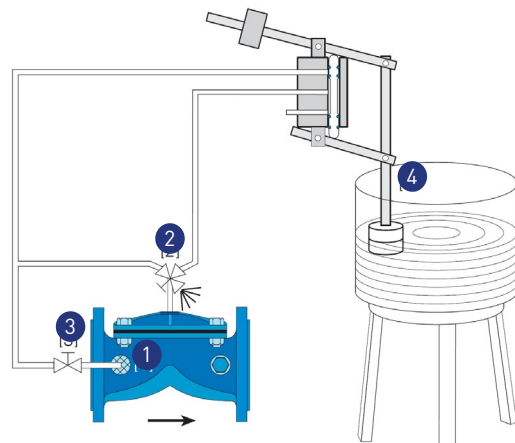

RAF-13 2-W Bi-Level Float Control Valve

Ref	Name
1	Self-cleaning screen filter
2	3-W valve
3	Cock valve
4	3-W Float pilot assembly

**RECOMMENDED FLOW**

Nominal Diameter		Flow Rate (m3/h)	
mm	inch	Normal	Intermittent
40	1.5	25	35
50	2	41	60
65	2.5	70	85
80D	3D	70	85
80	3	95	125
100D	4D	95	125
100	4	177	200
125D	5D	177	200
150D	6D	177	200
150	6	240	300
200	8	430	630
250	10	822	1025
300	12	822	1025
350D	14D	822	1025
350	14	1170	1600
400	16	1233	1650

Nominal diameter only, for full dimensions please refer to the Engineering department.

**FEATURES**

- Basic RAF valve two-layered Epoxy-polyester coated
- Self-cleaning screen filter
- 2-W brass pilot P-10
- Stainless steel float
- Stainless steel float rod (standard 1 m)
- 3-W selecting cock valve
- Reinforced plastic tubing

**OPTIONAL FEATURES:**

- Rilsan coating
- Large capacity external filter
- Stainless steel pilot P-10
- Stainless steel rod extension
- Copper and stainless steel tubing

**PLEASE SPECIFY**

- Maximum operating pressure (closed valve)
- Minimum and maximum flow rate
- Maximum water level
- Float rod length if not standard

# RAF SERIES HYDRAULIC VALVES FOR WATERWORKS

## RAF 1031

### Electric Float Control Valve, 3-W Metal Solenoid

The RAF 1031 is a Normally Closed (N.C) electric float control valve, activated by line pressure.

The electric circuit is switched by a float hanging over the water surface at the desired height.

When the water level drops below the float, the electric circuit is switched on and opens the valve through a solenoid valve. As the rising water reaches the maximum level, the solenoid is de-energized and the RAF 1031 closes.

The RAF 1031 is a non-modulating service valve, operating as an on/off valve.



#### MARKETS



Open field  
Irrigation



Water  
Transmission



Pump  
Station

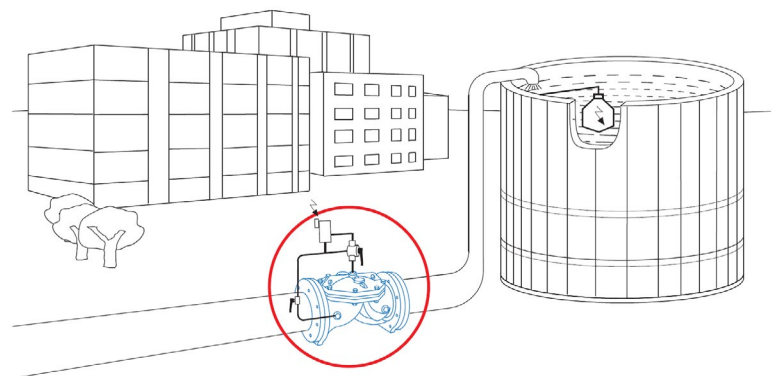

#### TECHNICAL DATA

**Fluid:** raw water or filtered water

**Nominal Diameter (DN):**  
from 40 to 400 mm (1.5" to 16")

**Available connections:** Flanged,  
Threaded or Grooved

**Nominal Pressure (PN):** 16 bar

**Medium Temperature:**  
up to 70 °C

**Body material:** Ductile Iron

**Standard Controls:** RAF 1031 electric float control valve controls with Raphael's 3-W solenoid valve. An electric circuit is switched On/Off by a dry contact float hanging over the water surface.

In case of power failure, the RAF 1031 remains tight-close to avoid an uncontrolled spill of water.

### TYPICAL APPLICATIONS

- Water level control.
- Best for remote or local control of reservoirs and water tanks level control when electricity is available.
- The valve can be located also above the upper water level of the tank

### ADJUSTMENT

Fix the float's cable to the reservoir's inner wall at the desired level. This fixation point will be in between minimum and maximum levels, allowing the float to turn up and down.

The length of electric cable left after the fixation between minimum and maximum water level preset.

**AUTOMATIC OPERATION:**

When the water level is low, switch the selecting cock to AUTO to connect the electric circuit. This energizes the solenoid, causing the RAF's control chamber to drain. As the water level rises and activates the electric float, the electric circuit disengages, de-energizing the solenoid. Line pressure is then directed to the control chamber through the solenoid. Consequently, the RAF 1031 closes, halting the water flow into the tank.

**MANUAL OPERATION:**

To open the valve overriding the float place the selecting cock in OPEN position.

To close the valve overriding the float place the selecting cock in CLOSE position.

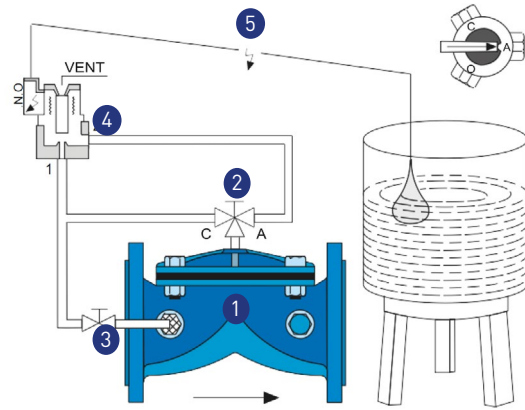

**RAF-1031 Electric Float Control Valve**

Ref	Name
1	Self-cleaning screen filter
2	3-W valve
3	Cock valve
4	3-W (N.O.) metal solenoid
5	Electric Float

**RECOMMENDED FLOW**

Nominal Diameter		Flow Rate (m3/h)	
mm	inch	Normal	Intermittent
40	1.5	25	35
50	2	41	60
65	2.5	70	85
80D	3D	70	85
80	3	95	125
100D	4D	95	125
100	4	177	200
125D	5D	177	200
150D	6D	177	200
150	6	240	300
200	8	430	630
250	10	822	1025
300	12	822	1025
350D	14D	822	1025
350	14	1170	1600
400	16	1233	1650

Nominal diameter only, for full dimensions please refer to the Engineering department.

**FEATURES**

- Basic RAF valve two-layered Epoxy-polyester coated
- Self-cleaning screen filter
- 3-W (N.O.) metal solenoid
- Electric float cable (w/10m)
- 3-W selecting cock valve
- Reinforced plastic tubing
- Power source 24 VAC50/60 Hz

**OPTIONAL FEATURES:**

- Rilsan coating
- Large capacity external filter
- Copper and stainless steel tubing
- Power source 110/220 VAC & 9/12/24 VDC

**PLEASE SPECIFY**

- Maximum operating pressure (closed valve)
- Electric source data if different than standard

# RAF SERIES HYDRAULIC VALVES FOR WATERWORKS

## RAF 60/62

### Pressure Reducing Control Valve, 2-W Mini Pilot

The RAF 60 pressure reducing valve is line pressure hydraulically actuated, 2-W pilot. The RAF 60 maintains constant downstream pressure, as set on the 2-W pressure reducing pilot, regardless of flow changes, or upstream pressure change.

The RAF 62 pressure reducing valve is line pressure hydraulically actuated, 2-W pilot. The 2-W pressure reducing pilot valve has a spring-loaded membrane, downstream sensitive and can be preset to a desirable downstream pressure.

The RAF 62 maintains a constant downstream pressure, as set on the 2-W pressure reducing pilot regardless of flow changes, or upstream pressure changes.

The 2-W pilot configuration together with Raphael's patented diaphragm enable smooth and precise downstream pressure control.



#### MARKETS



Open field  
Irrigation



Water  
Transmission



Pump  
Station

#### TECHNICAL DATA

**Fluid:** raw water or filtered water

**Nominal Diameter (DN):**  
from 40 to 400 mm (1.5" to 16")

**Available connections:** Flanged,  
Threaded or Grooved

**Nominal Pressure (PN):** 16 bar

**Setting Range:** 0.5 to 16 bar

**Medium Temperature:**  
up to 70 °C

**Body material:** Ductile Iron

**Standard Controls:** Pressure reducing valve controls with Raphael's 2-W pressure reducing brass pilot P-161 or P-162 reinforced plastic tubing and brass fittings.

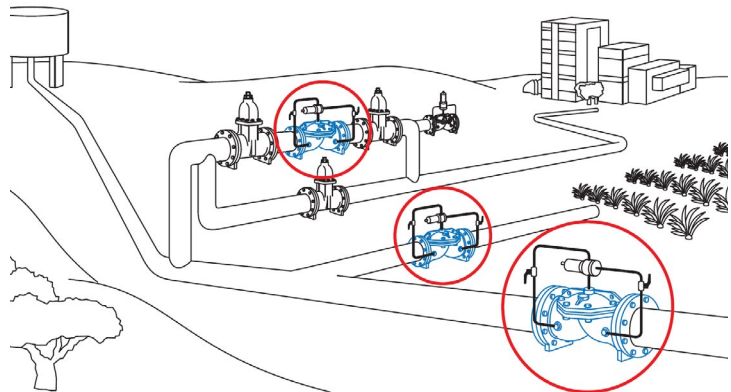

#### TYPICAL APPLICATIONS

- Water supply systems with medium pressure rating.
- Irrigation water distribution and field control.

#### ADJUSTMENT

Downstream pressure adjustment up to 16 bars.

For pressure setting by pilot screw adjustment, please refer to available springs list.

**AUTOMATIC OPERATION:**

When downstream pressure is lower than that of the pilot spring [pre-adjusted set point], the RAF's control chamber drains downstream and the RAF opens. When the downstream pressure rises above the preset spring load, the pilot's membrane is forced upwards closing the pilot's water passage. The RAF 60/62 then closes reducing downstream pressure.

**MANUAL OPERATION:**

To open the RAF 60/62, close cocks 1 and 2 and open the Vent. To close the valves, open cock 1 and close cock 2 and Vent (3).

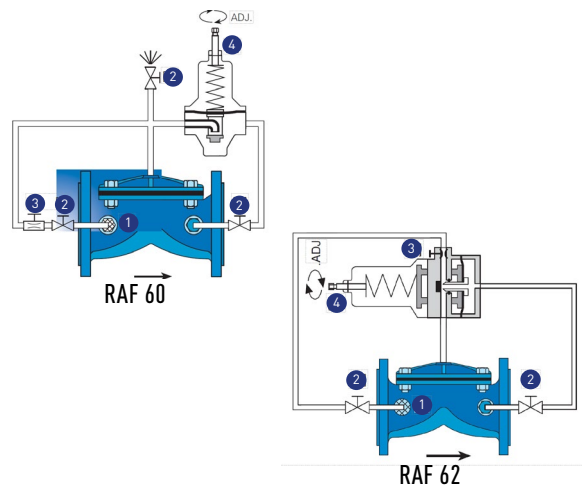

**SPRING SELECTION**

**RAF 60 - Pilot P-161**

Setting range [Bar]	Color of spring
2-10 (standard)	Green
0.5-4	Blue
0.5-6	Red
2-16	Yellow

**RAF 62 - Pilot P-162**

Setting range [Bar]	Color of spring
2-12 (standard)	Green
0.5-8	Red
2-16	Yellow

Ref	RAF 60	RAF 62
1	Self-cleaning screen filter	Self-cleaning screen filter
2	cock valve	cock valve
3	Needle valve	Built-in needle valve
4	2-w pilot P-161	2-w pilot P-162

**RECOMMENDED FLOW**

Nominal Diameter		Flow Rate (m3/h)
mm	inch	Max.
40	1.5	25
50	2	45
65	2.5	60
80-65-80	3-2.5-3	70
80	3	90
100-80-100	4-3-4	90
100	4	150
125-100-125	5-4-5	150
150-100-150	6-4-6	150
150	6	320
200	8	550
250	10	950
300	12	1000
350	14	1300
400	16	1400

**FEATURES RAF 60/62**

- RAF valve two-layered Epoxy-polyester coated
- Self-cleaning screen filter
- 2-W pilot P-161 (RAF 60)
- 2-W pilot P-162 (RAF 62)
- Brass needle valve (RAF 60)
- Reinforced plastic tubing
- Glycerin filled pressure gauge

**OPTIONAL FEATURES:**

- Rilsan coating
- Large capacity external filter
- Stainless steel pilot and needle valve
- Copper and stainless steel tubing
- Pressure check point

**PLEASE SPECIFY:**

- Minimum & maximum flow rates
- Normal line pressure

Nominal diameter only, for full dimensions please refer to the Engineering department.

# RAF SERIES HYDRAULIC VALVES FOR WATERWORKS

## RAF 63B

### Pressure Reducing Control Valve, 3-W Metal Pilot

The RAF 63B 3-W pressure reducing valve is line pressure hydraulically actuated, 3-W pilot.

The RAF 63B maintains a constant downstream pressure, as set on the 3-W reducing pilot, regardless of flow, or upstream pressure changes. The 3-W pilot configuration together with Raphael's patented diaphragm enable smooth and precise downstream pressure control.



#### MARKETS



Open field  
Irrigation



Water  
Transmission



Pump  
Station

#### TECHNICAL DATA

**Fluid:** raw water or filtered water

**Nominal Diameter (DN):**  
from 40 to 400 mm (1.5" to 16")

**Available connections:** Flanged,  
Threaded or Grooved

**Nominal Pressure (PN):** 16 bar

**Setting Range:** 0.5 to 16 bar

**Medium Temperature:**  
up to 70 °C

**Body material:** Ductile Iron

**Standard Controls:** RAF 63B  
pressure reducing valve controls  
with Raphael's 3-W brass pilot  
reinforced plastic tubing and brass  
fittings.

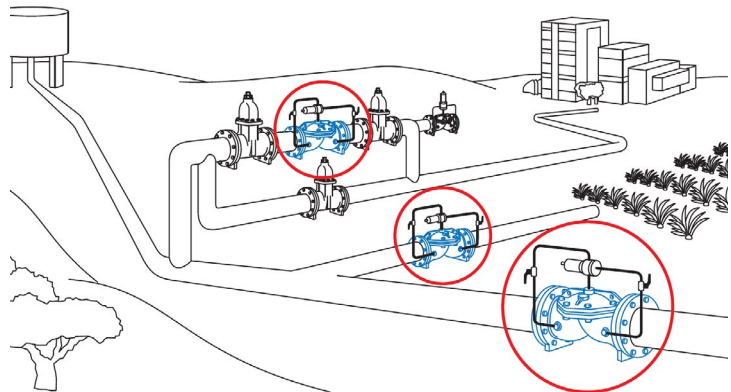

#### TYPICAL APPLICATIONS

- Water supply systems with medium pressure rating.
- Irrigation water distribution water treatment circulation and filtration network.
- The 3-W plastic pilot has a simple design that provides high corrosion resistance and cost effective prices

#### ADJUSTMENT

Downstream pressure adjustment up to 16 bars.

For pressure setting by pilot screw adjustment, please refer to available springs list.



**AUTOMATIC OPERATION:**

RAF Pressure Reducing Valve is activated by line pressure and controlled by a pilot valve. The pilot includes a spring-loaded membrane, which is exposed to the downstream [controlled] pressure. The displacement of the membrane due to downstream fluctuations defines the flow inside the pilot.

When the downstream pressure is lower than desired, the RAF valve is automatically directed to open. In the opposite case, it is automatically directed to close. When line pressure is inserted into the control chamber of the RAF valve [above its diaphragm] the valve closes.

When the control chamber drains the RAF valve opens due to the line pressure from below its diaphragm. As in three-way control configurations, the control chamber drains out, enabling the valve to open fully.

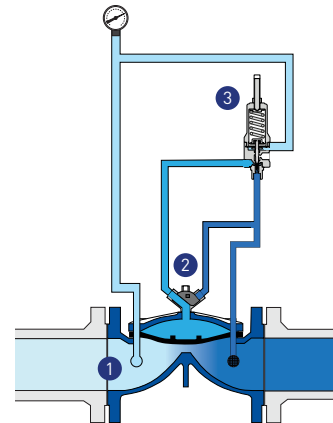

**RAF-63B 3-W Pressure Reducing Control Valve**

Ref	Name
1	Self-cleaning screen filter
2	3-W valve
3	3-W pilot P-683

**SPRING SELECTION**

Pilot P-683

Setting range [Bar]	Color of spring
2-12 (standard)	Green
0.5-8	Red
3-16	Yellow

**RECOMMENDED FLOW**

Nominal Diameter		Flow Rate (m3/h)	
mm	inch	Min.	Max.
40	1.5	1	25
50	2	3	41
65	2.5	4	70
80-65-80	3D	4	70
80	3	7	95
100-80-100	4D	7	95
100	4	15	177
125-100-125	5	15	177
150-100-150	6D	15	177
150	6	15	240
200	8	40	430
250	10	80	822
300	12	100	822
350-300-350	14D	100	822
350	14	200	1170
400	16	200	1233

Nominal diameter only, for full dimensions please refer to the Engineering department.

**FEATURES**

- RAF valve two-layered Epoxy-polyester coated
- Self-cleaning screen filter
- 3-W pilot P-683
- 3-W Selecting cock valve
- Reinforced plastic tubing
- Glycerin filled pressure gauge
- Power source - 24V (AC) 50/60 Hz

**OPTIONAL FEATURES:**

- Rilsan coating
- Large capacity external filter
- Stainless steel pilot and needle valve
- Copper and stainless steel tubing
- Pressure check point

**PLEASE SPECIFY:**

- Minimum & maximum flow rates
- Normal line pressure
- Set point (downstream) pressure

# RAF SERIES HYDRAULIC VALVES FOR WATERWORKS

## RAF 68/682

### Pressure Reducing/Sustaining Control Valve, 2-W Metal Pilot

The RAF 68/682 pressure reducing & sustaining valve is line pressure hydraulically actuated, 2-W pilot.

The RAF 68/682 pressure reducing & sustaining valve is line pressure hydraulically actuated, 2-W pilot. The RAF 68/682 maintains a minimum upstream pressure, as set on the 2-W pressure sustaining pilot and a maximum downstream as set on the 2-W pressure reducing pilot, regardless of flow changes.

The 2-W pilot configuration together with Raphael's patented diaphragm enable smooth and precise pressure control.



#### MARKETS



Open field  
Irrigation



Water  
Transmission



Pump  
Station

#### TECHNICAL DATA

**Fluid:** raw water or filtered water

**Nominal Diameter (DN):**  
from 40 to 400 mm (1.5" to 16")

**Available connections:** Flanged,  
Threaded or Grooved

**Nominal Pressure (PN):** 16 bar

**Setting Range:** 0.5 to 6 bar

**Medium Temperature:**  
up to 70 °C

**Body material:** Ductile Iron

**Standard Controls:** RAF 68/682 pressure reducing & sustaining valve controls with Raphael's 2-W brass pilots, with built-in needle valve, reinforced plastic tubing and brass fittings.

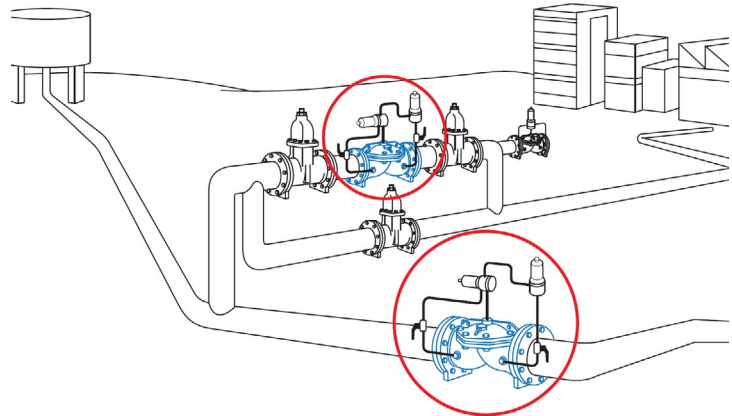

### TYPICAL APPLICATIONS

- Water supply systems with medium pressure rating.
- Use the valve to define two pressure zones along a supply line.
- Irrigation water distribution and field control.

### ADJUSTMENT

Use needle valve a to control the RAF 68/682 operational speed. Adjust the sustained pressure by the adjusting screw. See table of available springs below.

**AUTOMATIC OPERATION:**

When line pressure is low, the pilots are positioned as shown. The RAF control chamber is connected to the line pressure and the RAF is closed. When the line pressure rises and overcomes the spring of the sustaining pilot, the pilot's membrane moves upward to open its port. Then the RAF's control chamber drains downstream through the right pilot, the RAF valve opens and reduces the upstream pressure.

When the line pressure reduces, the pilot closes, as does the RAF. If the downstream pressure is higher than the set point of the reducing pilot, the reducing pilot's membrane moves upward and closes its port. Again, the RAF control chamber is connected to the upstream pressure and the RAF closes.

**MANUAL OPERATION:**

To open the RAF, close cocks 1 and 2 and open the Vent.  
To close the RAF, open cock 1 and close cocks 2 and the Vent.

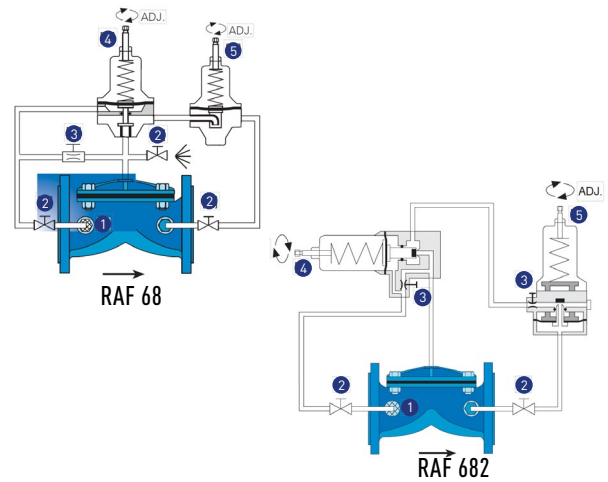

RAF-68/682 2-W Pressure Reducing & Sustaining Control Valve

**SPRING SELECTION**

**Pilot P-182/ P-162**

Setting range [Bar]	Color of spring
2-12 (standard)	Green
0.5-8	Red
3-16	Yellow (ONLY P-182)

**Pilot P-161, P-181**

Setting range [Bar]	Color of spring
2-10 (standard)	Green
0.5-4	Blue
0.5-6	Red
2-16	Yellow

Ref	RAF 68	RAF 682
1	Self-cleaning screen filter	Self-cleaning screen filter
2	Cock valve	Cock valve
3	Needle valve	Built-in needle valve
4	2-W pilot P-181	2-W pilot P-182
5	2-W pilot P-161	2-W pilot P-162

**RECOMMENDED FLOW**

Nominal Diameter		Flow Rate (m3/h)
mm	inch	Max.
40	1.5	25
50	2	41
65	2.5	70
80-65-80	3D	70
80	3	95
100-80-100	4D	95
100	4	177
125-100-125	5	177
150-100-150	6D	177
150	6	240
200	8	430
250	10	822
300	12	822
350-300-350	14D	822
350	14	1170
400	16	1233

**FEATURES**

- RAF valve two-layered Epoxy-polyester coated
- Self-cleaning screen filter
- 2-W pilot P-182 (RAF 682)
- 2-W pilot P-162 (RAF 682)
- 2-W pilot P-161 (RAF 68)
- 2-W pilot P-181 (RAF 68)
- Needle valve
- Reinforced plastic tubing
- Glycerin filled pressure gauge

**OPTIONAL FEATURES:**

- Rilsan coating
- Large capacity external filter
- Stainless steel pilot with built-in needle valve
- Copper and stainless steel tubing
- Pressure check point

**PLEASE SPECIFY:**

- Minimum & maximum flow rates
- Normal line pressure
- Set point (sustain) pressure

Nominal diameter only, for full dimensions please refer to the Engineering department.

# RAF SERIES HYDRAULIC VALVES FOR WATERWORKS

## RAF 683B

### Pressure Reducing/Sustaining Control Valve, 3-W Metal Pilot

The RAF 683B pressure reducing & sustaining valve is line pressure hydraulically actuated, 3-W pilot.

The RAF 683B maintains a minimum upstream pressure, as set on the 3-W pressure sustaining pilot and a maximum downstream as set on the 3-W pressure reducing pilot, regardless of flow changes.

The 3-W pilots configuration together with Raphael's patented diaphragm enable smooth and precise pressure control.



#### MARKETS



Open field  
Irrigation



Water  
Transmission



Pump  
Station

#### TECHNICAL DATA

**Fluid:** raw water or filtered water

**Nominal Diameter (DN):**  
from 40 to 400 mm (1.5" to 16")

**Available connections:** Flanged,  
Threaded or Grooved

**Nominal Pressure (PN):** 16 bar

**Setting Range:** 0.5 to 6 bar

**Medium Temperature:**  
up to 70 °C

**Body material:** Ductile Iron

**Standard Controls:** RAF 683B  
pressure reducing & sustaining  
valve controls with Raphael's 3-W  
P-683 pilots, reinforced plastic  
tubing and brass fittings

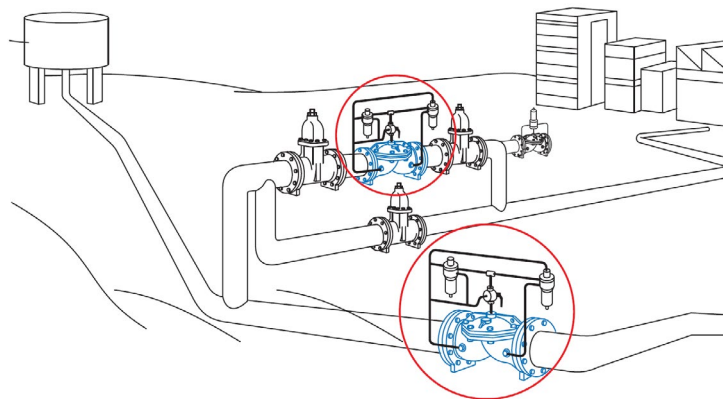

### TYPICAL APPLICATIONS

- Water supply systems with medium pressure rating.
- Use the valve to define two pressure zones along a supply line.
- Irrigation water distribution and field control.

### ADJUSTMENT

Minimum upstream and maximum downstream pressure adjustment up to 16 bars.

For pressure setting by pilot screw adjustment, please refer to available springs list.

**AUTOMATIC OPERATION:**

The three-way cock should be positioned in A. When the upstream pressure is low, both pilots are in the lower position as shown. The line pressure flows through ports 4-2 of the sustaining pilot [the left one], flips the shuttle valve open, and flows into the RAF control chamber. The RAF closes to sustain upstream pressure. When the upstream pressure rises above the set point, the membrane of the left pilot moves upward and opens its ports 2-3. The RAF control chamber drains this way [the shuttle valve remains open]. Thus, the RAF opens.

When the downstream pressure rises above the preset reducing level [right pilot], the right pilot membrane moves upwards. The line pressure then flows through its ports 3-2, Flips the shuttle valve to the left and Flows into the RAF's control chamber. The RAF closes. The downstream pressure reduces.

**MANUAL OPERATION:**

Use the three-way cock to close or open the RAF by turning the handle to C or O, respectively

**SPRING SELECTION**

**Pilot P-683S/683**

Setting range [Bar]	Color of spring
2-12 (standard)	Green
0.5-8	Red
3-16	Yellow

**RECOMMENDED FLOW**

Nominal Diameter		Flow rate (m³/h)
mm	inch	Max.
40	1.5	25
50	2	41
65	2.5	70
80-65-80	3D	70
80	3	95
100-80-100	4D	95
100	4	177
125-100-125	5	177
150-100-150	6D	177
150	6	240
200	8	430
250	10	822
300	12	822
350-300-350	14D	822
350	14	1170
400	16	1233

Nominal diameter only, for full dimensions please refer to the Engineering department.

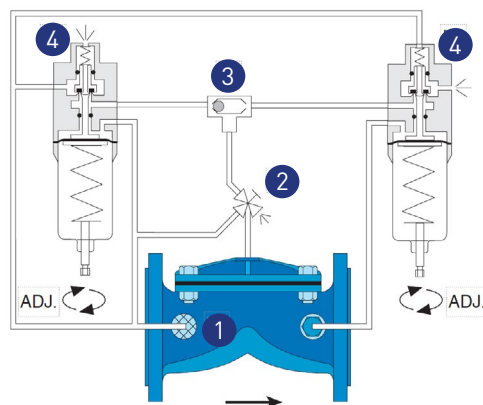

**RAF-683B** 3-W Pressure Reducing & Sustaining Control Valve

Ref	Name
1	Self-cleaning screen filter
2	3-W valve
3	Shuttle valve
4	3-W pilot P-683S
5	3-W pilot P683R

**FEATURES**

- RAF valve two-layered Epoxy-polyester coated
- Self-cleaning screen filter
- 3-W pilot P-683S (configured as sustaining)
- 3-W pilot P-683R (configured as reducing)
- 3-W selecting cock valve
- Reinforced plastic tubing
- Glycerin filled pressure gauge

**OPTIONAL FEATURES:**

- Rilsan coating
- Large capacity external filter
- Stainless steel pilot
- Copper and stainless steel tubing
- Pressure check point

**PLEASE SPECIFY:**

- Minimum & maximum flow rates
- Normal line pressure
- Set point (sustain) pressure

# RAF SERIES HYDRAULIC VALVES FOR WATERWORKS

## RAF 80/82 Pressure Sustaining Relief Control Valve 2-W Metal Pilot

The RAF 80/82 pressure sustaining/relief valve is line pressure hydraulically actuated, 2-W pilot. The RAF 80/82 maintains a minimum upstream pressure, as set on the 2-W pressure sustaining pilot, regardless of flow changes.

The RAF 80/82 pressure sustaining/relief valve will fully open should upstream pressure exceed 2-W pilot set pressure.

The 2-W pilot configuration together with Raphael's patented diaphragm enable smooth and precise upstream pressure control.



### MARKETS



Open field  
Irrigation



Water  
Transmission



Pump  
Station

### TECHNICAL DATA

**Fluid:** raw water or filtered water

**Nominal Diameter (DN):**  
from 40 to 400 mm (1.5" to 16")

**Available connections:** Flanged,  
Threaded or Grooved

**Nominal Pressure (PN):** 16 bar

**Setting Range:** 0.5 to 16 bar

**Medium Temperature:**  
up to 70 °C

**Body material:** Ductile Iron

**Standard Controls:** RAF 80  
pressure sustaining/relief valve  
controls with Raphael's 2-W metal  
pilot, reinforced plastic tubing and  
brass fittings.

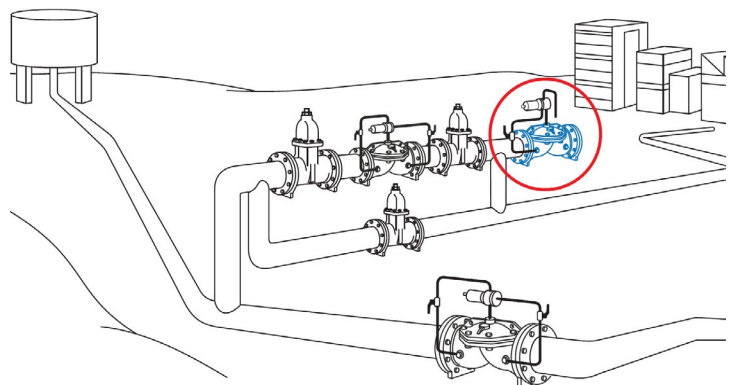

### TYPICAL APPLICATIONS

- Water supply systems with medium pressure rating.
- Use the valve to maintain a constant upstream pressure and to avoid an undesirable high pressure.
- Irrigation water distribution and field control.

### ADJUSTMENT

Minimum upstream pressure adjustment up to 16 bars.

For pressure setting by pilot screw adjustment, please refer to available springs list.

**AUTOMATIC OPERATION:**

When the upstream pressure is lower than that of the sustained pressure set point, the RAF control chamber is connected to the line, as illustrated. The RAF is closed.

When the upstream pressure rises above the set point, the pilot's membrane is forced upward. Port 1 opens, the control chamber of the RAF drains downstream and the RAF 80 opens to relieve the excessive pressure.

**MANUAL OPERATION:**

To open the RAF 80/82, close cocks 1 and 2 and open the Vent.  
To close the RAF 80/82 open cock 1 and close cock 2 and Vent.

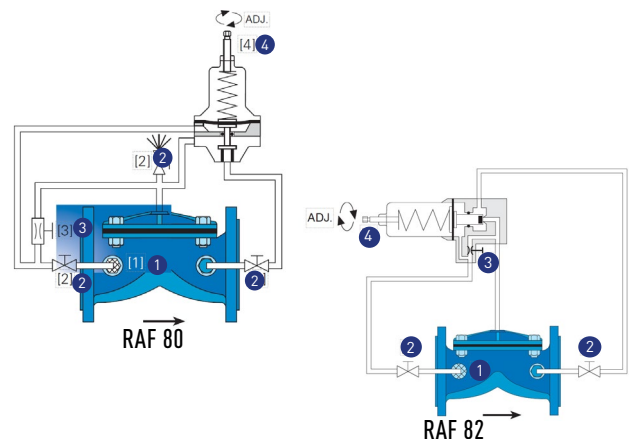

RAF-80/82 - 2-W Pressure Sustaining Relief Control Valve

**SPRING SELECTION**

**Pilot P-181 (RAF 80)**

Setting range [Bar]	Color of spring
2-10 (standard)	Green
0.5-4	Blue
0.5-6	Red
2-16	Yellow

**Pilot P-182 (RAF 82)**

Setting range [Bar]	Color of spring
2-12 (standard)	Green
0.5-8	Red
3-16	Yellow

Ref	RAF 80	RAF 82
1	Self-cleaning screen filter	Self-cleaning screen filter
2	Cock valve	Cock valve
3	Needle valve	Built-in needle valve
4	2-W pilot P-181	2-W pilot P-182

**RECOMMENDED FLOW**

Nominal Diameter		Recommended Flow Rate [m³/h]	
mm	inch	Min.	Max.
50	2	3	41
65	2.5	4	70
80-65-80	3D	4	70
80	3	7	95
100-80-100	4D	7	95
100	4	15	177
125-100-125	5	15	177
150-100-150	6D	15	177
150	6	15	240
200	8	40	430
250	10	80	822
300	12	100	822
350-300-350	14D	100	822
350	14	200	1170
400	16	200	1233

**FEATURES**

- RAF valve two-layered Epoxy-polyester coated
- Self-cleaning screen filter
- 2-W pilot P-182
- 2-W pilot P-181
- Reinforced plastic tubing
- Glycerin filled pressure gauge

**OPTIONAL FEATURES:**

- Rilsan coating
- Large capacity external filter
- Stainless steel pilot with built-in needle valve
- Copper and stainless steel tubing
- Pressure check point

**PLEASE SPECIFY:**

- Minimum & maximum flow rates
- Normal line pressure
- Set point (sustain) pressure

Nominal diameter only, for full dimensions please refer to the Engineering department.

## RAF SERIES HYDRAULIC VALVES FOR WATERWORKS

### RAF 80Q

#### Quick Pressure Relief Control Valve 2-W Metal Pilot

The RAF 80Q Quick pressure relief valve is line pressure hydraulically actuated by 2-W quick pressure relief pilot.

The 2-W relief pilot has an upstream sensitive spring-loaded membrane, that can be preset to maintain a desirable upstream pressure.

The RAF 80Q is quickly fully open when upstream pressure exceed the 2-W pilot set pressure. The 2-W pilot configuration together with Raphael's patented diaphragm enable quick and high flow relief valve opening.



#### MARKETS



Open field  
Irrigation



Water  
Transmission



Pump  
Station

#### TECHNICAL DATA

**Fluid:** raw water or filtered water

**Nominal Diameter (DN):**  
from 40 to 400 mm (1.5" to 16")

**Available connections:** Flanged,  
Threaded or Grooved

**Nominal Pressure (PN):** 16 bar

**Setting Range:** 0.5 to 16 bar

**Medium Temperature:**  
up to 70 °C

**Body material:** Ductile Iron

**Standard Controls:** RAF 80Q  
Quick relief valve controls  
with Raphael's 2-W relief pilot,  
reinforced plastic tubing and brass  
fittings.

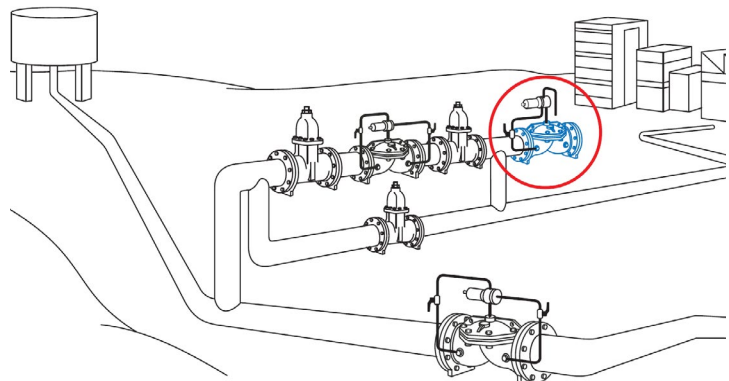

#### TYPICAL APPLICATIONS

- Water supply systems with medium pressure rating.
- Use the valve to protect water systems from quickly rising excessive pressure.
- Irrigation water distribution and field control.

#### ADJUSTMENT

Use needle valve to control the RAF 80Q operational speed. (The needle valve should be between 0.5 to 1 turns open).

Adjust the sustained pressure by the adjusting screw.

See table of available springs below.



**AUTOMATIC OPERATION:**

When line pressure is low, the pilot is closed as illustrated, the RAF 80Q remains closed by line pressure.

When line pressure is higher than the set point of the pilot, the spring is biased, enabling the membrane to move upward under the line pressure. The inner port of the pilot opens, the RAF control chamber drains through the vent. Then, the RAF 80Q opens and relieves the excessive pressure.

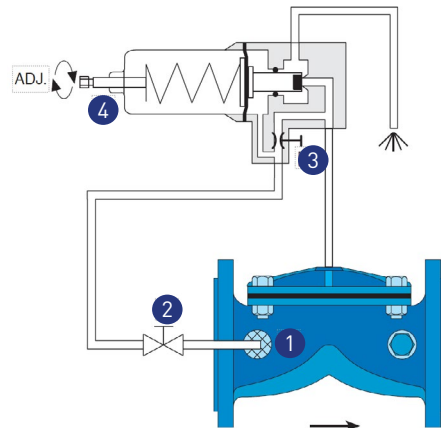

RAF-80Q - Quick Pressure Relief Control Valve

**SPRING SELECTION**

**Pilot P-181 (6"-16")**

Setting range [Bar]	Color of spring
2-10 (standard)	Green
0.5-4	Blue
0.5-6	Red
2-16	Yellow

**Pilot P-182 (1"-4")**

Setting range [Bar]	Color of spring
2-12 (standard)	Green
0.5-8	Red
3-16	Yellow

Ref	Name
1	Self-cleaning screen filter
2	2 Cock valve
3	3 Built-in needle valve
4	4 2-W relief pilot
5	5 Orifice plate

**RECOMMENDED FLOW**

Nominal Diameter		Flow rate (m³/h)
mm	inch	Max.
40	1.5	35
50	2	60
65	2.5	85
80-65-80	3D	85
80	3	125
100-80-100	4D	125
100	4	200
125-100-125	5	200
150-100-150	6D	200
150	6	300
200	8	630
250	10	1025
300	12	1025
350-300-350	14D	1025
350	14	1600
400	16	1650

**FEATURES**

- RAF valve two-layered Epoxy-polyester coated
- Self-cleaning screen filter
- 2-W relief pilot
- Reinforced plastic tubing
- Pressure check point

**OPTIONAL FEATURES:**

- Rilsan coating
- Large capacity external filter
- Stainless steel pilot
- Stainless steel needle valve
- Copper and stainless steel tubing

Nominal diameter only, for full dimensions please refer to the Engineering department.

## RAF SERIES HYDRAULIC VALVES FOR WATERWORKS

### RAF 83B

#### Pressure Sustaining Control Valve, 3-W Metal Pilot

RAF 83B pressure sustaining valve is line pressure hydraulically actuated, 3-W pilot.

The RAF 83B maintains a minimum upstream pressure, as set on the 3-W pilot, regardless of flow changes.

The RAF 83B pressure sustaining valve will fully open should upstream pressure exceed 3-W pilot set pressure.

The 3-W pilot configuration together with Raphael's patented diaphragm enable smooth and precise upstream pressure control.



#### MARKETS



Open field  
Irrigation



Water  
Transmission



Pump  
Station

#### TECHNICAL DATA

**Fluid:** raw water or filtered water

**Nominal Diameter (DN):**  
from 40 to 400 mm (1.5" to 16")

**Available connections:** Flanged,  
Threaded or Grooved

**Nominal Pressure (PN):** 16 bar

**Setting Range:** 0.5 to 16 bar

**Medium Temperature:**  
up to 70 °C

**Body material:** Ductile Iron

**Standard Controls:** RAF 83B  
pressure sustaining/relief valve  
controls with Raphael's 3-W  
P-683S pilot, reinforced plastic  
tubing and brass fittings.

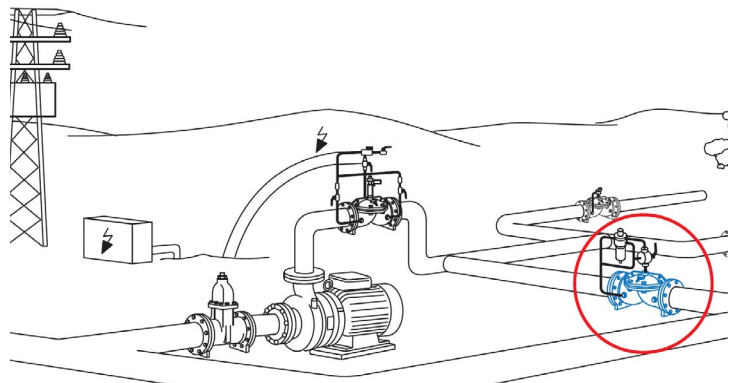

#### TYPICAL APPLICATIONS

- Water supply systems with medium pressure rating.
- Use the valve to maintain a constant upstream pressure and to avoid an undesirable high pressure.
- Irrigation water distribution and field control

#### ADJUSTMENT

Minimum upstream pressure adjustment up to 16 bars.

For pressure setting by pilot screw adjustment, please refer to available springs list.

**AUTOMATIC OPERATION:**

The 3-way cock should be positioned at A. When the upstream pressure is low, the pilot's membrane is in its lower position as illustrated. The RAF 83B control chamber is exposed to line pressure through the ports 4-2 of the pilot. The RAF closes to sustain the upstream pressure. When the upstream pressure is higher than preset, it overcomes the pilot spring and force the pilot membrane to move upward. Then ports 2-3 open and port 4 closes. The RAF 83B control chamber drains and the valve opens to relieve the excessive pressure downstream.

**MANUAL OPERATION:**

Use the 3-way cock to close or open the RAF by turning the handle to the C or O positions, respectively.

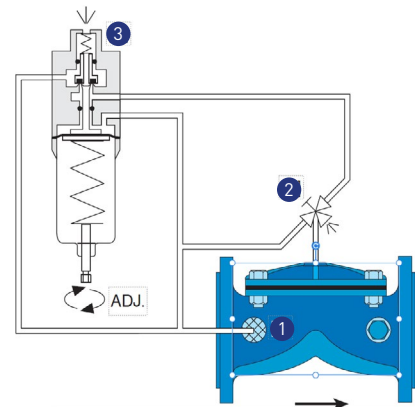

RAF-83B 3-W Pressure Sustaining Control Valve

Ref	Name
1	Self-cleaning screen filter
2	3-W valve
3	3-W pilot P-683S

**SPRING SELECTION**

**Pilot P-683S**

Setting range [Bar]	Color of spring
2-12 (standard)	Green
0.5-8	Red
3-16	Yellow

**RECOMMENDED FLOW**

Nominal Diameter		Recommended Flow Rate [m <sup>3</sup> /h]	
mm	inch	Min.	Max.
40	1.5	1	25
50	2	3	41
65	2.5	4	70
80-65-80	3D	4	70
80	3	7	95
100-80-100	4D	7	95
100	4	15	177
125-100-125	5	15	177
150-100-150	6D	15	177
150	6	15	240
200	8	40	430
250	10	80	822
300	12	100	822
350-300-350	14D	100	822
350	14	200	1170
400	16	200	1233

Nominal diameter only, for full dimensions please refer to the Engineering department.

**FEATURES**

- RAF valve two-layered Epoxy-polyester coated
- Self-cleaning screen filter
- 3-W pilot P-683S
- 3-W selecting cock valve
- Reinforced plastic tubing
- Glycerin filled pressure gauge

**OPTIONAL FEATURES:**

- Rilsan coating
- Large capacity external filter
- Stainless steel pilot
- Copper and stainless steel tubing
- Pressure check point

# RAF SERIES HYDRAULIC VALVES FOR WATERWORKS

## RAF 70 Flow Rate Control Valve, 2-W Metal Pilot

The RAF 70 flow rate control valve is line pressure hydraulically actuated, 2-W pilot. Normally the valve is partly open to allow a constant flow rate. The head loss across the orifice is proportional to the flow rate.

The RAF 70 maintains a constant preset flow rate, as set on the 2-W flow rate pilot and a calibrated orifice, regardless of pressure changes.

The 2-W pilot configuration together with Raphael's patented diaphragm enable smooth and precise flow rate control.



### MARKETS



Open field  
Irrigation



Water  
Transmission



Pump  
Station

### TECHNICAL DATA

**Fluid:** raw water or filtered water

**Nominal Diameter (DN):**  
from 40 to 400 mm (1.5" to 16")

**Available connections:** Flanged,  
Threaded or Grooved

**Nominal Pressure (PN):** 16 bar

**Medium Temperature:**  
up to 70 °C

**Body material:** Ductile Iron

**Standard Controls:** RAF 70 flow rate valve controls with Raphael's 2-W P-100 metal pilot, reinforced plastic tubing and brass fittings.

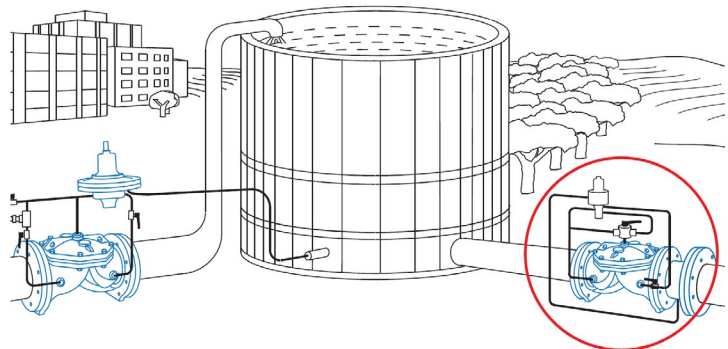

### TYPICAL APPLICATIONS

- Water supply systems with medium pressure rating.
- Use RAF 70 to eliminate excessive pumping or to limit the water demand.
- Irrigation water distribution and field control.

### ADJUSTMENT

Flow rate adjustment + 10% flow rate.

**AUTOMATIC OPERATION:**

In normal flow rate, the RAF 70 is open. The head loss across the orifice is low, and the pilot membrane is maintained in its lower position, as shown.

The line pressure flows through the open pilot, ports 1-2, and drains downstream. When the flow rate through the valve increases, so does the head loss across the orifice. When the head loss is higher than preset, the Adjustment pilot membrane is pushed upward closing port 2.

The RAF is forced to close by line pressure. The flow rate decreases as does the head loss across the orifice. The pilot's membrane moves back and the RAF gradually reopens.

**MANUAL OPERATION:**

To open the RAF 70, close cocks 1 and 2 and open the Vent.  
To close the RAF open cock 1 and close cock 2 and the Vent.

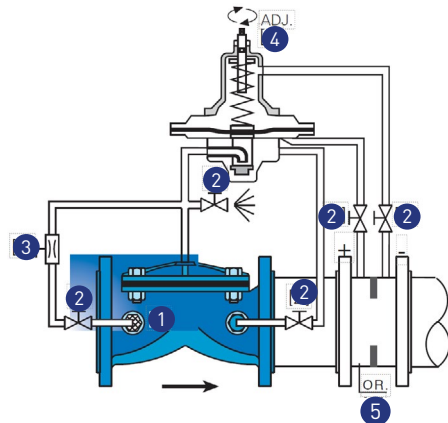

RAF-70 2-W Flow Rate Control Valve

Ref	Name
1	Self-cleaning screen filter
2	Cock valve
3	3 Needle valve
4	4 2-W pilot P-100
5	5 Orifice plate

**RECOMMENDED FLOW**

Nominal Diameter		Flow rate (m³/h)
mm	inch	Max.
40	1.5	25
50	2	41
65	2.5	70
80-65-80	3D	70
80	3	95
100-80-100	4D	95
100	4	177
125-100-125	5	177
150-100-150	6D	177
150	6	240
200	8	430
250	10	822
300	12	822
350-300-350	14D	822
350	14	1170
400	16	1233

**FEATURES**

- RAF valve two-layered Epoxy-polyester coated
- Self-cleaning screen filter
- 2-W metal pilot P-100
- Needle valve
- Reinforced plastic tubing
- Orifice plate

**OPTIONAL FEATURES:**

- Rilsan coating
- Large capacity external filter
- 3-W metal pilot P-103
- Copper and stainless steel tubing

**PLEASE SPECIFY:**

- Maximum permissible pressure drop
- Flow rate (set point)

Nominal diameter only, for full dimensions please refer to the Engineering department.

# RAF SERIES HYDRAULIC VALVES FOR WATERWORKS

## RAF 20 Pump Protection Control Valve

The RAF 20 valve regulates the pressure level during the start and shut-off of a pump to protect the pumping assembly and the downstream network. The RAF 20 is applicable, with slightly different layout and switching, for either vertical [deep well] or horizontal [booster] pumps.

In both configurations, the RAF 20 is connected electrically to the pump's control panel. For booster pumps control the RAF 20 is installed on the main line downstream of the pump. Generally the valve protects the booster pump and its engine by sustaining the pressure in starting and shutoff, and function as a check valve otherwise. The valve protects the pump in case of power shutdown by sustaining the pressure downstream the pump.

In deep well configurations, the RAF 20 is installed on a tee branch off the main line. It functions basically as a pressure relief. Letting a low pressure in starting and shut-off, and closes other wise to enable a gradual pressure buildup. In case of emergency shutdown, the RAF 20 opens to relieve pressure from the vertical pump.



### MARKETS



Open field  
Irrigation



Water  
Transmission



Pump  
Station

### TECHNICAL DATA

**Fluid:** raw water or filtered water

**Nominal Diameter (DN):**  
from 40 to 400 mm (1.5" to 16")

**Available connections:** Flanged,  
Threaded or Grooved

**Nominal Pressure (PN):** 16 bar

**Medium Temperature:**  
up to 70 °C

**Body material:** Ductile Iron

**Standard Controls:**

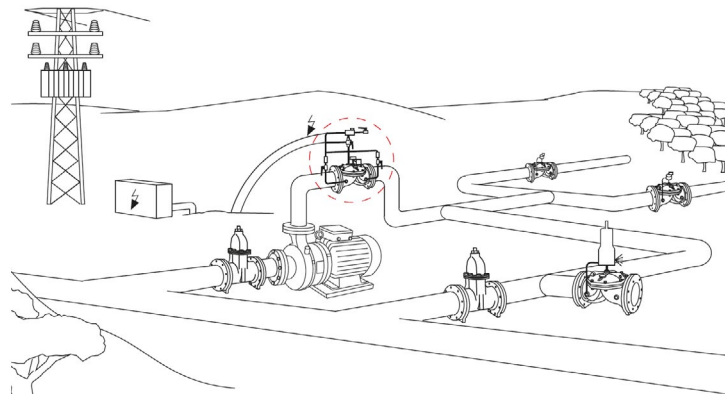

### TYPICAL APPLICATIONS

RAF 20 controls the out flow of booster pump. The pump's intake is on the main line at the left. Note also a quick relief valve- RAF 80Q on the right. Use pump control Hydraulic valve with any pump to protect the pump housing, the pumping accessories and water lines. Protection is needed in both horizontal and vertical pumps. Consult RAPHAEL engineers for the most suitable layout, switching and sizing of pump control valve for your application.

### BOOSTER PUMP CONFIGURATION

By default of the normally closed RAF valve, the line automatic: The three-way cock should be positioned at A. Normally, the power is turned OFF and the valve is closed, as illustrated. When the pump is turned ON, the solenoid is energized and its plunger flips to the left. Port 1 of the solenoid closes and the vent opens. The control chamber of the RAF 20 drain, the RAF opens gradually, allowing the pump to achieve higher outflow. As the RAF 20 opens, the indicator rises to its upper position. When the electric power is turned OFF, from any reason, the solenoid de-energizes, its plunger flips back to the right, and the RAF 20 gradually closes. The pressure is sustained. In normal shutdown the pump is turned off electrically by the limit switch only after the RAF 20 is completely closed. In case of unexpected shutdown the RAF 20 closes at the same time. Check valves are located on each side of the RAF 20 to ensure its closure.

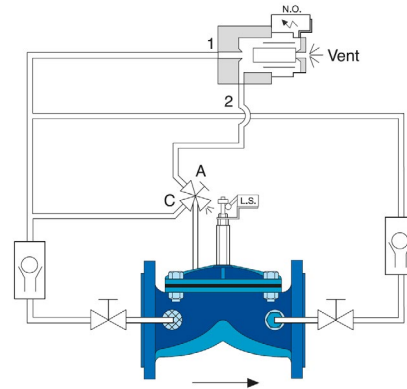

RAF-20 Pump Protection Control Valve

### DEEP WELL CONFIGURATION

#### AUTOMATIC OPERATION:

The RAF is installed on a tee branch off the main line. The RAF 20 is normally open to allow low pressure and build up of full pumping. As the pump is turned ON, a timer starts a countdown and eventually de-energizes the solenoid, the valve closes gradually under increasing pressure. When the power is turned OFF, the RAF 20 opens to relieve the pressure gradually.

#### MANUAL OPERATION:

Use the three-way cock to open or close the RAF 20, by turning the handle to O or C, respectively.

### WELL PUMP CONTROL VALVE ELECTRIC SCHEME

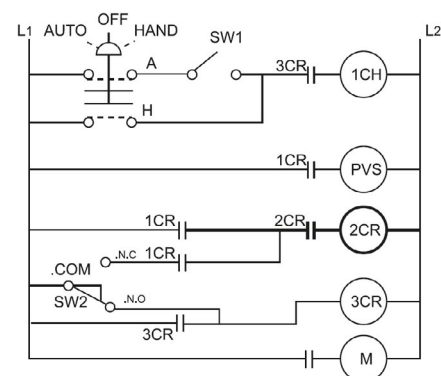

- AUTO OFF-HAND** - SELECTOR SWITCH
- 1CR - 2CR - 3CR** - RELAY, DPST NORMALLY OPEN
- SW1** - SWITCH, REMOTE START, AUTOMATIC
- SW2** - SWITCH, SPDT VALVE LIMIT SWITCH (CONNECT TO N.C. TERMINAL)
- PVS** - PILOT VALVE SOLENOID (HOOKED IN PARALLEL)
- M** - PUMP MOTOR STARTED

### RECOMMENDED FLOW

Nominal Diameter		Flow Rate (m3/h)	
mm	inch	Normal	Intermittent
40	1.5	25	35
50	2	45	60
65	2.5	60	80
80-65-80	3-2.5-3	70	100
80	3	90	120
100-80-100	4-3-4	90	120
100	4	150	180
125-100-125	5-4-5	150	200
150-100-150	6-4-6	150	200
150	6	320	400
200	8	550	750
250	10	950	1150
300	12	1000	1200
350	14	1300	1500
400	16	1400	1600

Nominal diameter only, for full dimensions please refer to the Engineering department.

### FEATURES

- Basic RAF valve two-layered Epoxy-polyester coated
- Self-cleaning screen filter
- Brass check valves
- Indicator with limit switch assembly
- 3-W 24V AC N.O. Solenoid valve 50/60 Hz
- Selecting cock valve (3 port ball valve)
- Reinforced plastic tubing

### OPTIONAL FEATURES:

- Rilsan coating
- Large capacity external filter
- 110 V, 220V AC & 9V, 12V, 24V DC
- Copper and stainless steel tubing

### PLEASE SPECIFY

- Electric source (if not standard)
- Pump configuration (booster or deep well pump)

# RAF SERIES HYDRAULIC VALVES FOR WATERWORKS

## RAF 40/43 Altitude Control Valve

RAF 40/43 is used to maintain a preset water level of reservoirs or water tanks. The RAF valve is activated by line pressure, and is commanded by an Altitude pilot. The Altitude pilot is mounted on the valve, therefore there is no installation required on top of the reservoir.

The RAF 40 valve controls the maximum water level of the reservoir by controlling the maximum water column pressure generated by the water inside the water storage.

The RAF 40/43 stays open as long as the water level of the reservoir is below a preset level.

The RAF 40 is a modulating service valve, operating as an on/off valve.



### MARKETS



Open field  
Irrigation



Water  
Transmission



Pump  
Station

### TECHNICAL DATA

**Fluid:** raw water or filtered water

**Nominal Diameter (DN):**  
from 40 to 400 mm (1.5" to 16")

**Available connections:** Flanged,  
Threaded or Grooved

**Nominal Pressure (PN):** 16 bar

**Medium Temperature:**  
up to 70 °C

**Body material:** Ductile Iron

**Standard Controls:** Float level  
control valve controls with altitude  
metal pilot.

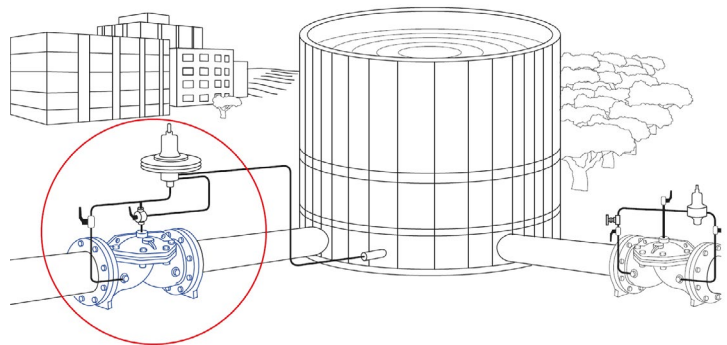

### TYPICAL APPLICATIONS

- Reservoirs and water tanks level controls, especially in high rise reservoirs.
- Line pressure provides energy suitable for operation.
- Remote operation of hydraulic valve
- Due to its simple design it is virtually maintenance free.

### ADJUSTMENT

Adjust the desired altitude within the allowable range using the adjustment screw. Turn the screw counter clockwise to lower the control altitude.



### RAF 40 - 2-Way Altitude Control Hydraulic Valve

Especially fit when high precision is requested and small variation between minimum and maximum levels. Altitude ranges: 15m, 25m & 40m.

#### AUTOMATIC OPERATION

When the water level in the reservoir is lower than the pre-set altitude, the RAF 40 opens. The line pressure is used to control the valve flow from the upstream through the RAF's control chamber to the downstream. When the water level raises, the pressure under the pilot's membrane raises consequently. When the water reaches its maximum pre-set level, the pressure overcomes the pilot's spring, the pilot's membrane moves upwards and closes the drain. The RAF 40 fully closes due to the line pressure. When the water level drops, the pilot opens

#### MANUAL OPERATION

Open the RAF 40 overriding the pilot by closing cocks 1 & 2 and opening the vent. Close the RAF 40 overriding the pilot by closing the cock 2 & vent and opening cock 1.

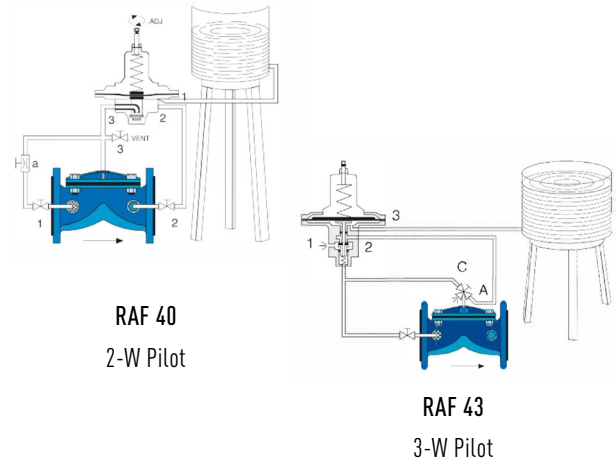

RAF 40  
2-W Pilot

RAF 43  
3-W Pilot

RAF-40/ 43 Altitude Control Valve

### RAF40/43 - 3-Way Altitude Control Hydraulic Valve

Especially fit for low height water tanks. Altitude ranges: 8m, 15m & 30m.

#### AUTOMATIC OPERATION

When the water level in the reservoir is lower than the preset altitude, the RAF 43 opens. When the water level raises, the pressure head under the pilot's membrane raises consequently. When the water reaches its maximum preset level, the pressure overcomes the pilot's spring. When the pilot's membrane moves upwards and connects the control chamber to line pressure, the RAF 43 fully closes. When the water level in the reservoir drops again, the valve's control chamber drains to the atmosphere through the pilot's vent. Line pressure supply is closed in parallel. The RAF 40/43 opens, due to the line pressure.

#### MANUAL OPERATION

To open the valve overriding the float place the Selecting Cock in Open position. To close the valve overriding the float place the Selecting Cock in Close position.

## RECOMMENDED FLOW

Nominal Diameter		Flow Rate (m <sup>3</sup> /h)
mm	inch	Max.
40	1.5	25
50	2	45
65	2.5	60
80-65-80	3-2.5-3	70
80	3	90
100-80-100	4-3-4	90
100	4	150
125-100-125	5-4-5	150
150-100-150	6-4-6	150
150	6	320
200	8	550
250	10	950
300	12	1000
350	14	1300
400	16	1400

#### FEATURES:

- Basic RAF valve two-layered Epoxy-polyester coated
- Self-cleaning screen filter
- 2-Way altitude metal pilot ALT2 (RAF 40)
- 3-Way altitude metal pilot ALT3 (RAF 43)
- Spring set for reservoir maximum level 15 m
- Reinforced plastic tubing

#### OPTIONAL FEATURES:

- Rilsan coating
- Large capacity external filter
- 2-Way altitude St.St. pilot
- Spring set for reservoir max.level 25 & 40 m
- Copper and stainless steel tubing

Nominal diameter only, for full dimensions please refer to the Engineering department.

# RAF SERIES HYDRAULIC VALVES FOR WATERWORKS

## RAF 88 Surge Anticipating Control Valve, 3-W Metal Pilot

RAF 88 is adjusted to eliminate hazardous pressure surges typical of water hammer conditions. A water hammer is caused by an abrupt shutoff of a pump or rapid closure of a main valve, causing a fast propagation of low-pressure front, followed by an extremely high-pressure back-wave. A Series of pressure waves, each one composed of alternating low and high pressure is created within a few seconds. RAF 88 is a piloted hydraulic valve activated by line pressure. The valve has two pilots, for high and low pressure. Under normal conditions, the RAF 88 is closed. It opens when the line pressure drops below a preset pressure, in anticipation to the following surge, and remains open until the fluctuations subside.

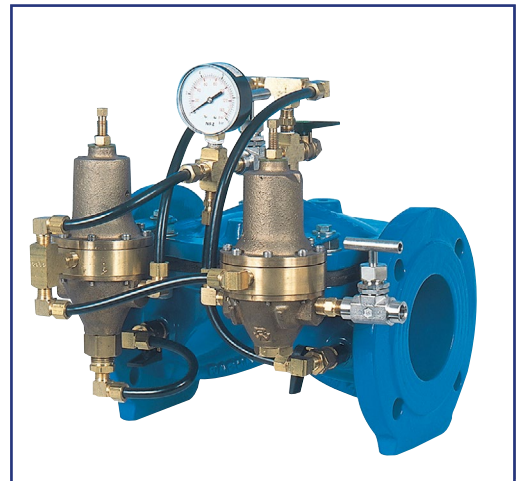

### MARKETS



Open field  
Irrigation



Water  
Transmission



Pump  
Station

### TECHNICAL DATA

**Fluid:** raw water or filtered water

**Nominal Diameter (DN):**  
from 40 to 400 mm (1.5" to 16")

**Available connections:** Flanged,  
Threaded or Grooved

**Nominal Pressure (PN):** 16 bar

**Setting Range:** 0.5 to 16 bar

**Medium Temperature:**  
up to 70 °C

**Body material:** Ductile Iron

**Standard Controls:**

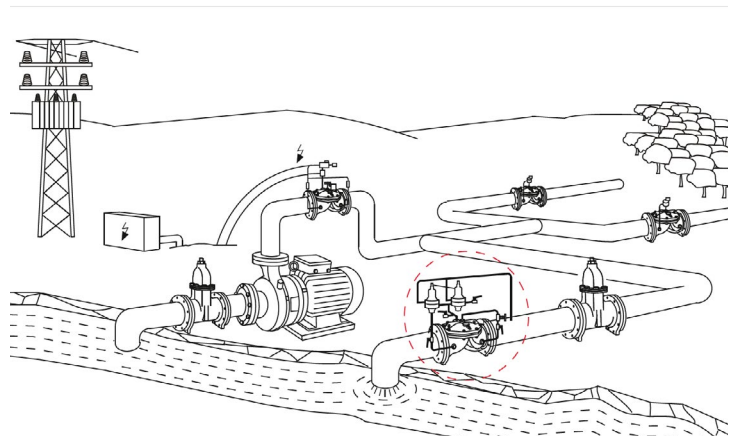

### TYPICAL APPLICATIONS

- RAF 88 is located next to a booster pump to protect the supply line downstream of the pump from water hammer damages.
- Use a surge-anticipating valve to protect water lines against water hammer damages.
- Uphill supply lines of considerable length and large diameter pipes are more susceptible to water hammer damages.

### ADJUSTMENT

Use needle valve a-b to control the RAF operational speed.  
Adjust the low and high pilot's set points by the adjusting screws.  
See list of available springs below.

**AUTOMATIC OPERATION:**

The RAF 88 is normally closed. Ensure that all cock valves [except the vent] are fully open. Normally, line pressure is higher than the set point of the low-pressure pilot [the left one], but lower than that of the high-pressure pilot [the right one].

Thus, ports 2 in both pilots are closed.

There is no flow from the main line to the pilots. The RAF control chamber is connected directly to the line pressure through needle valve a. The RAF is closed. When line pressure drops below the lower set point, the spring of the low-pressure pilot [left] push the pilot's membrane downward and on the way opens port 2, as shown in the drawing. The right pilot does not change.

The RAF control chamber drains out through port 2 -Vent b of the left pilot. The RAF 88 opens in anticipation to a surge. The pressure drop is soon followed by a surge, which closes the left pilot but opens the right one [the high-pressure pilot] at the same time. The RAF control chamber now drains through ports 2-3 of the right pilot and thus remains open. The high pressure wave is allowed to flow through. After the surges subside, and the line pressure returns to normal level, both pilots close and RAF 99 follows suit.

**MANUAL OPERATION:**

To open the RAF 88, close cocks 1,2 and 4 and open the Vent.

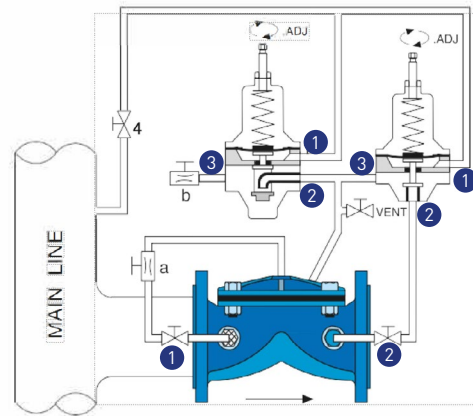

RAF-88 Surge Anticipating Control Valve

**SPRING SELECTION**

**Pilot P-181**

Setting range [Bar]	Color of spring
2-10 (standard)	Green
0.5-4	Blue
0.5-6	Red
2-16	Yellow

**Pilot P-161**

Setting range [Bar]	Color of spring
2-10 (standard)	Green
0.5-4	Blue
0.5-6	Red
2-16	Yellow

**RECOMMENDED FLOW**

Nominal Diameter		Recommended Flow Rate [m³/h]	
mm	inch	Min.	Max.
40	1.5	1	25
50	2	3	41
65	2.5	4	70
80-65-80	3D	4	70
80	3	7	95
100-80-100	4D	7	95
100	4	15	177
125-100-125	5	15	177
150-100-150	6D	15	177
150	6	15	240
200	8	40	430
250	10	80	822
300	12	100	822
350-300-350	14D	100	822
350	14	200	1170
400	16	200	1233

Nominal diameter only, for full dimensions please refer to the Engineering department.

**FEATURES**

- RAF valve two-layered Epoxy-polyester coated
- Self-cleaning screen filter
- 2-W pilot P-181
- 2-W pilot P-161B
- Brass needle valves
- Reinforced plastic tubing
- Glycerin filled pressure gauge

**OPTIONAL FEATURES:**

- Rilsan coating
- Large capacity external filter
- 2-W high capacity pilot P-181-3/4
- 2-W high capacity pilot P-161B-3/4
- Copper and stainless steel tubing

## RAF SERIES HYDRAULIC VALVES FOR WATERWORKS

### RAF 90 Anti Burst Control Valve, 2-W Metal Pilot

RAF 90 is a Normally Open piloted hydraulic valves activated by line pressure. Only in case of flow rate higher than a preset maximum, due to a burst or excessive demand downstream, the RAF 90 are automatically closed down and can re-open manually.

The actual flow rate through the RAF 90 is determined by comparing the headloss across an orifice plate.

The valve is closed down by a hydraulic relay which guarantees a tight closing and manual re-opening.



#### MARKETS



Open field  
Irrigation



Water  
Transmission



Pump  
Station

#### TECHNICAL DATA

**Fluid:** raw water or filtered water

**Nominal Diameter (DN):**  
from 40 to 400 mm (1.5" to 16")

**Available connections:** Flanged,  
Threaded or Grooved

**Nominal Pressure (PN):** 16 bar

**Setting Range:** 0.5 to 16 bar

**Medium Temperature:**  
up to 70 °C

**Body material:** Ductile Iron

**Standard Controls:** RAF 90 Anti  
Burst valve control with Raphael's  
2-W metal pilot P-100, reinforced  
plastic tubing and brass fittings.

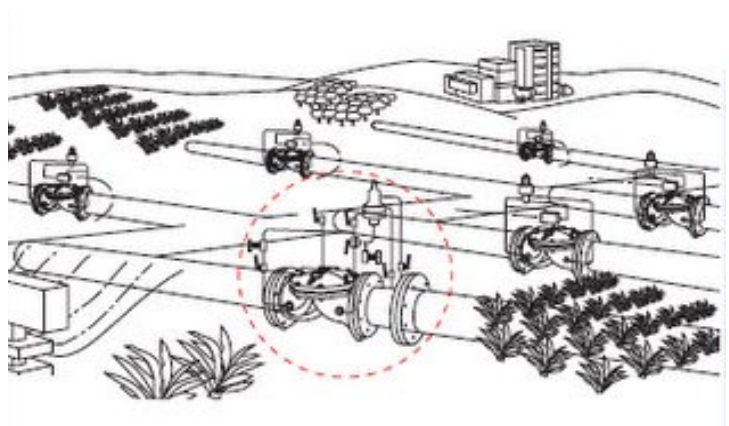

#### TYPICAL APPLICATIONS

- RAF 90 valve controls a water supply network downhill of a reservoir.
- Use Anti-Burst Control valve to eliminate water loss and damage due to piping burst. The valve is best in networks susceptible to burst due to old piping, vandalism or pressure surge. The RAF 90 features a metal pilot valve and hydraulic relay to ensure precise and reliable response in general use.

#### ADJUSTMENT

Use the needle valve a to control the RAF 90 operational speed.

Adjust the operational set point by the adjusting screw.

See the list of available springs below.

**AUTOMATIC OPERATION:**

Set the manual override handle of the hydraulic relay on automatic position [designated R2]. In normal flow rate, the pilot is closed, as shown. The RAF control chamber is allowed to drain out through the relay's vent. The RAF 90 is fully open. When the head loss across the orifice exceeds the preset level, the pilot membrane is pushed upward with its plunger. The line pressure flowing via pilot ports 3-4 flips the hydraulic relay to its other position [designated R1]. The line pressure is then directed to the RAF's control chamber, and the RAF closes. After the problem is fixed, re-open the RAF by re-setting the hydraulic relay manually and shift back to auto position.

**MANUAL OPERATION:**

Use the manual override option of the hydraulic relay.

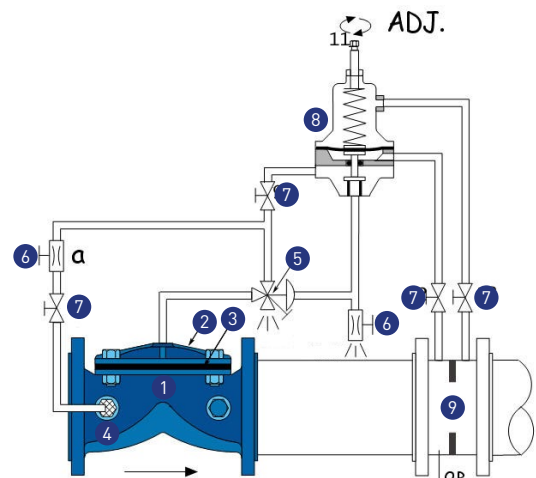

RAF-90 Anti Burst Control Valve, 2 Way Metal Pilot

Ref	Name
1	Body
2	Cover
3	Diaphragm
4	Filter
5	Accelerator Relay 3-Way
6	Needle Valve
7	Cock 2-Way valve
8	3-Way metal Pilot 90
9	Orifice

**RECOMMENDED FLOW**

Nominal Diameter		Recommended Flow Rate [m³/h]	
mm	inch	Min.	Max.
40	1.5	1	25
50	2	3	41
65	2.5	4	70
80-65-80	3D	4	70
80	3	7	95
100-80-100	4D	7	95
100	4	15	177
125-100-125	5	15	177
150-100-150	6D	15	177
150	6	15	240
200	8	40	430
250	10	80	822
300	12	100	822
350-300-350	14D	100	822
350	14	200	1170
400	16	200	1233

**FEATURES**

- RAF valve two-layered Epoxy-polyester coated
- Self-cleaning screen filter
- 2-W metal pilot P-100
- Orifice plate
- 3-W hydraulic relay
- Reinforced plastic tubing

**OPTIONAL FEATURES:**

- Rilsan coating
- Large capacity external filter
- 3-W metal pilot P-100
- Copper and stainless steel tubing

**PLEASE SPECIFY:**

- Maximum flow rate (set point)

Nominal diameter only, for full dimensions please refer to the Engineering department.



**FIRE PROTECTION**



**IRRIGATION**



**WATERWORKS**



**SMART SOLUTIONS**

**RAPHAEL VALVES INDUSTRIES (1975) LTD**, founded in 1949, is the first Israeli manufacturer of water control valves. RAPHAEL's research department constantly strives to introduce new and innovative products and solutions for water control systems including water works, fire-protection, irrigation systems and other fields.

**RAPHAEL Valves Industries (1975) Ltd.**

North Industrial Zone

Or Akiva, 3065401

POBox 555, Israel

**Phone:** +972 4 6263555

**E-mail:** info@raphael-valves.com

**Website:** www.raphael-valves.com

