

RAPHAEL

Product brochure

# FIRE HYDRANTS



RAPHAEL FP

# HYDRANT VALVES

**FHT - 2"**

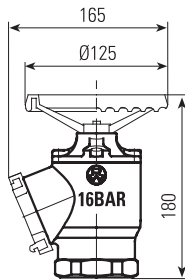

**FHT - 3"**

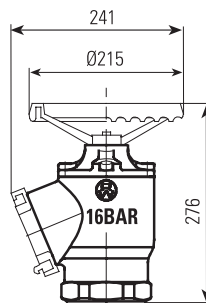

**FHF - 3"**

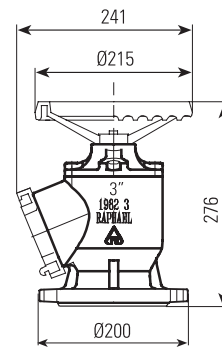

**FH13 - 4"**

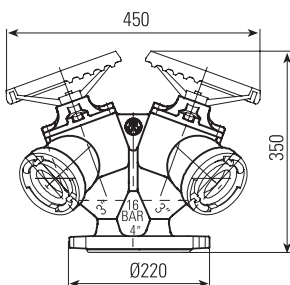

**FH12 - 6"**

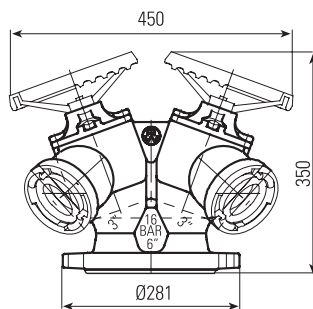

- RAPHAEL has been producing a wide range of fire hydrant valves for many years
- Innovative and sophisticated design are carried out according to the Israeli Standards requirements and to the Israel Firement's Association
- The valve seal disc, which is rubber vulcanized, guarantees complete sealing, and high reliability
- The bronze seat option provides a secure and accurate sealing
- All the valve's range body is made of cast one piece
- Valve design enables very low closing torque
- Protection against corrosion is provided by oven-baked painting
- High wear resistance
- Low head loss
- Special shape outlet preventing fire hose bending
- Unrising spindle
- Sealing between spindle and lid by o-ring which guarantees waterproofing for many years
- Stainless steel stem and stainless bolts for high reliability and resistance corrosion
- Flange connections: ASTD, ANSI, DIN

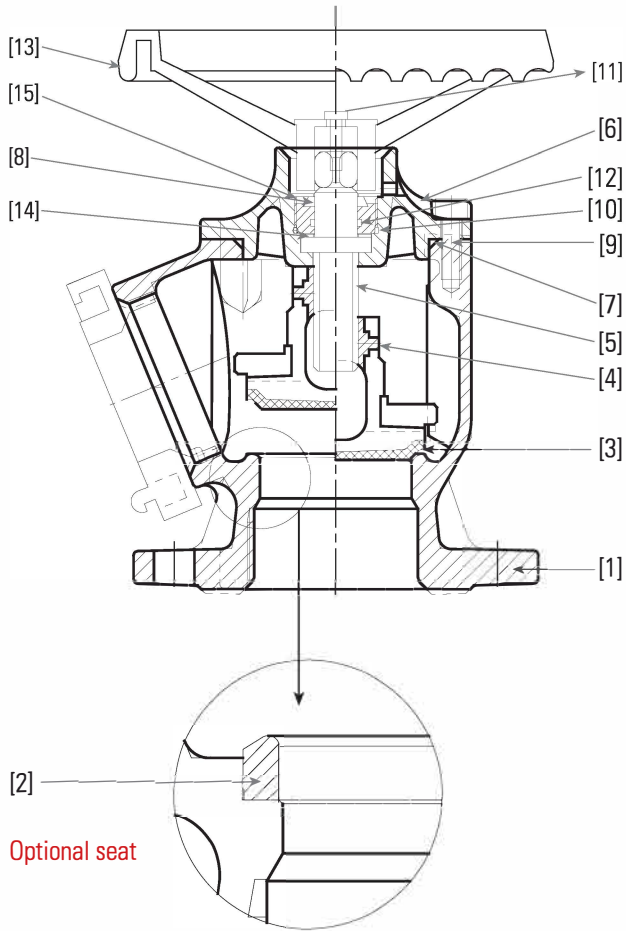

Item No.	Parts	MATERIAL
1	Body	Cast Iron
2	Seat (optional)	Cast Iron (Bronze)
3	Seal Disc	Cast Iron / Bronze + Rubber
4	Nut	Bronze
5	Spindle	Stainless Steel
6	Cover	Cast Iron
7	"O" Ring	Rubber
8	Dust Shield	Rubber
9	Bolt	Stainless Steel
10	"O" Ring	Rubber
11	Bolt	Hexagon Head
12	"O" Ring	Rubber
13	Wheel	Aluminium
14	Bearing Washer	Teflon
15	Protection Washer	Okolon

### Pressure-Loss chart for Fire Hydrant valves

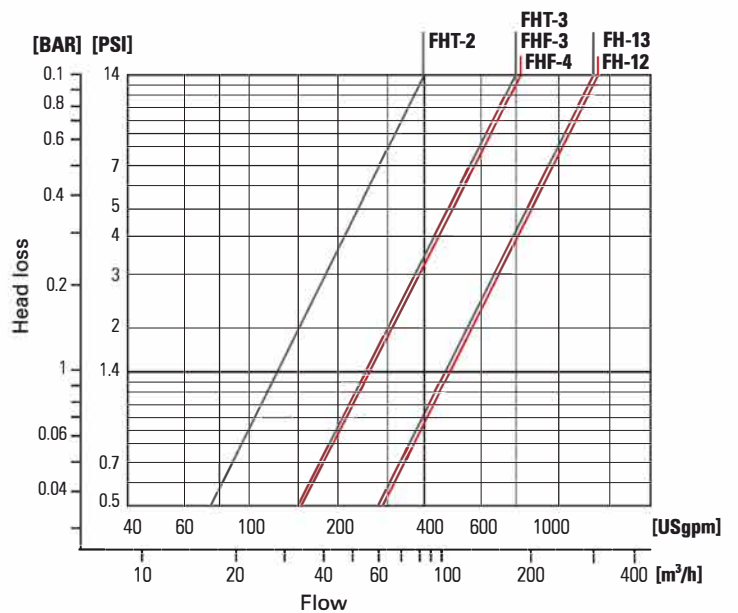

# Fire Hydrant

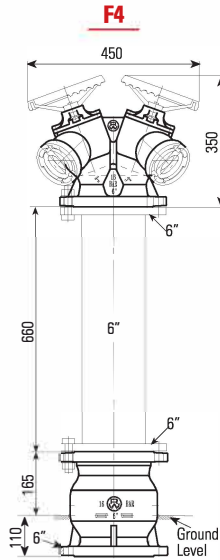
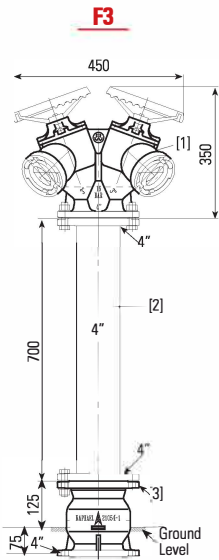
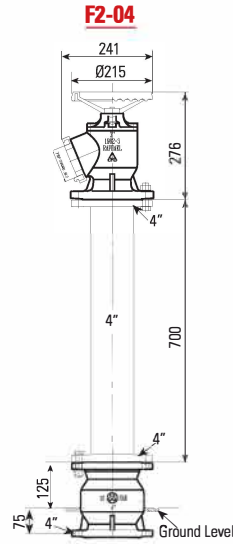
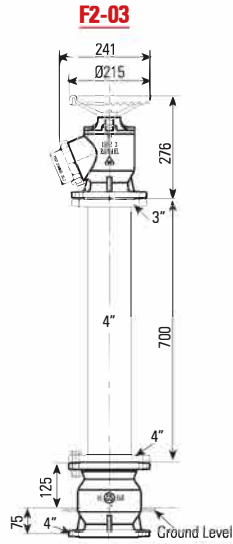
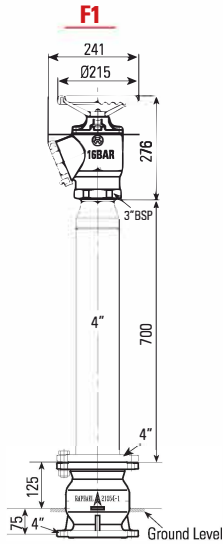

- [1]. Fire Hydrant
- [2]. Standpipe
- [3]. Breakage Device

Pressure-Loss chart for complete Fire Hydrant

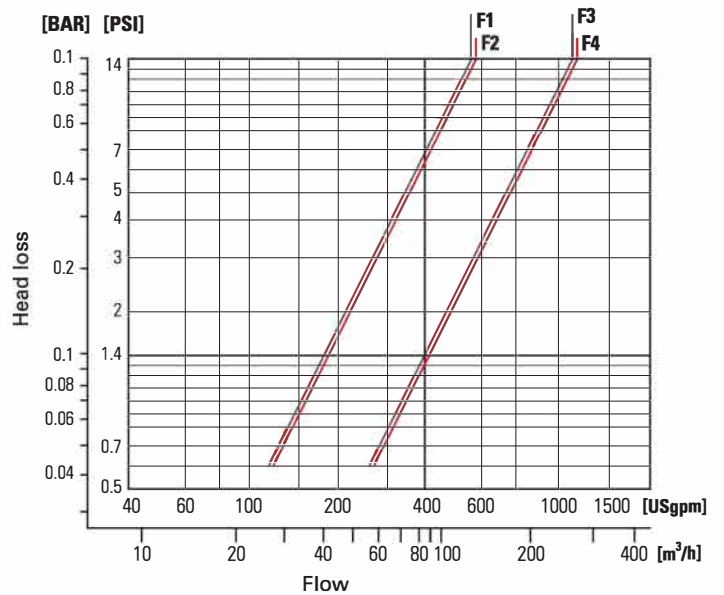



# Breakage Device F-21

**Function:** fire hydrant water outlet prevention in case of mechanical damage

- One PC body construction
- High reliability
- Low head loss
- No need for special tooling in installation.

1	Body	Cast Iron
2	Ball	Rubber Lined Allminum
3	Bol TS	Stainless Steel
4	Cover	Cast Iron
5	O-Ring	NBR

1	Body	Cast Iron
2	Ball	Rubber Lined Allminum
3	Bol TS	Stainless Steel
4	Cover	Cast Iron
5	O-Ring	NBR

1	Bottom Body	Cast Iron
2	Ball	Rubber Lined Aluminum
3	Bol TS	Stainless Steel
4	Nuts	Stainless Steel
5	Washers	Stainless Steel
6	Upper Body	Cast Iron
7	Ball Support	Stainless Steel
8	O-Ring	NBR

**F21-4"**

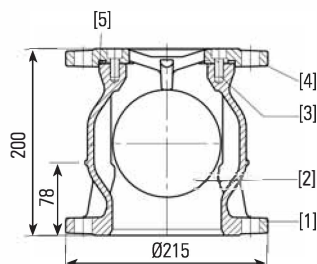

**F21-6"**

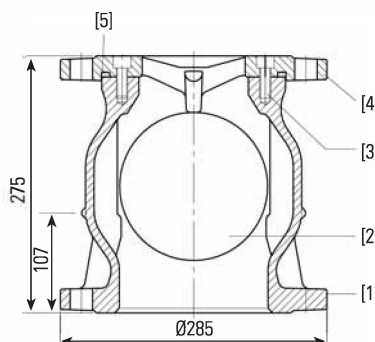

**F21-8"**

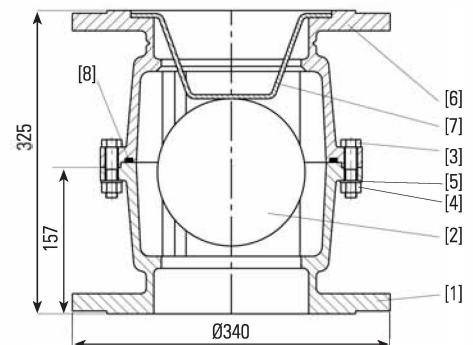

## Pressure Reduction Hydrant Valve RAF 60FP - conforms with NFPA 14 Directives Std. Sizes - DN40 - DN150

### Description

This application serves as a reliable constant pressure reducing valve for fire hoses that conforms with NFPA 14 Directives, limiting downstream pressure regardless of varying pressure and/or flow upstream of the RAF60FP control valve

### Typical Applications

- Power, Oil & Gas fire fighting hydrants
- Aviation fire fighting hydrants
- Industrial & High rise building fire fighting hydrants

### Features

- No metallic internal mechanism subject to corrosion, long term reliability
- One-piece diaphragm without internal metal spring
- In-line maintenance, no need for valve removal during maintenance
- Opening speed control
- Simple intuitive operation & adjustment
- High Built RILSAN coating, improved corrosion protection of valve

### Optional Features

- Flanged, grooved or threaded ends
- Storz quick-coupling hydrant connector
- Manual on-off valve



Dual Head Hydraulic Control Riser



Single Head Hydraulic Control Riser

## Dimensions of RAF & RAF-A

### RAF (Inline)

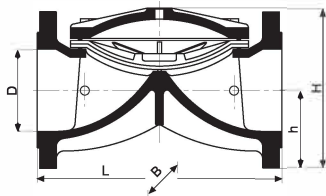

Connection	Nominal Diameter		L	H	B	h	Weight
	[mm]	[inch]					
Thread/Grooved	40	1.5	159	80	96	29	1.8
	50	2	190	100	125	38	3.9
Flange	50	2	190	159	165	76	7.9
Thread/Grooved	65	2.5	216	110	125	46	6.7
	65	2.5	216	173	185	80	10.1
Thread/Grooved	80-50-80	3-2-3	230	125	125	50	5.0
	Flange	80-50-80	3-2-3	230	175	200	100
Thread/Grooved	80-65-80	3-2.5-3	244	127	138	50	5.4
	Flange	80-65-80	3-2.5-3	216	192	200	92
Thread/Grooved	80	3	290	138	200	50	10.4
	Flange	80	3	283	200	200	100
Flange	100-80-100	4-3-4	283	222	222	111	20.1
Thread/Grooved	100	4	346	220	230	60	16.5
	Flange	100	4	305	220	230	99
Flange	125-100-125	5-4-5	305	243	250	120	29.5
Flange	150-100-150	6-4-6	325	285	285	143	35.8
Flange	150	6	406	295	300	142	48.5

### RAF-A (Angle)

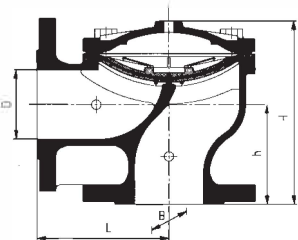

Connection	Nominal Diameter		L	H	B	h	Weight
	[mm]	[inch]					
Thread/Grooved	50	2	90	150	125	81	4.2
Flange	50	2	112	159	165	77	8.1
Thread/Grooved	65	2.5	117	160	125	83	7.0
	Flange	65	2.5	122	160	185	83
Thread/Grooved	80-50-80	3-2-3	110	146	125	72	4.9
	Flange	80-50-80	3-2-3	140	200	200	100
Thread/Grooved	80-65-80	3-2.5-3	130	170	140	86	6.2
	Flange	80-65-80	3-2.5-3	130	215	200	115
Thread/Grooved	80	3	148	205	200	107	12.0
	Flange	80	3	154	210	200	115
Flange	100-80-100	4-3-4	155	225	220	110	21.0
Thread/Grooved	100	4	150	227	230	118	15.9
	Flange	100	4	177	230	230	113
Flange	150	6	218	315	300	148	48.7



**FIRE PROTECTION**



**IRRIGATION**



**WATERWORKS**



**SMART SOLUTIONS**

**RAPHAEL VALVES INDUSTRIES (1975) LTD**, founded in 1949, is the first Israeli manufacturer of water control valves. RAPHAEL's research department constantly strives to introduce new and innovative products and solutions for water control systems including water works, fire-protection, irrigation systems and other fields.

**RAPHAEL Valves Industries (1975) Ltd.**

North Industrial Zone

Or Akiva, 30600

POBox 555, Israel

**Phone:** +972 4 6263555

**E-mail:** info@raphael-valves.com

**Website:** www.raphael-valves.com

