



IOM RAF 40

2-Way Altitude Control Valve

1 1/2" - 12"



Jan-24

DESCRIPTION

This modulating, altitude level control valve is an automatic control valve designed to open as water level drops and close shut at the levels determined by the pilot valve adjustment. Sensitivity is pre-set at 0.5 m and tank elevations available are 15/25/40 meters.

INSTALLATION

- Before installing the valve, flush the pipeline to remove scale, dirt and other particles that might affect the valve's performance.
- Install the valve as indicated by the arrow on the valve's cover, showing flow direction.
- It is recommended to install isolation valves (butterfly valves type B7G) upstream and downstream the control valve.
- Close two way valves 5 & 8. Open two way valve 6 and turn on water supply to the Raf. The Raf should be tight close.
- Check for leaks; tighten bolts & fittings if necessary.
-

PARTS LIST

1. Body
2. Cover
3. Diaphragm
4. Self-Flushing "Finger" Filter
5. Two-way valve
6. Two-way valve
7. Needle valve
8. Two-way valve
9. Three-way Altitude metal pilot ALT2
10. Altitude adjusting screw
11. Pressure sensor port

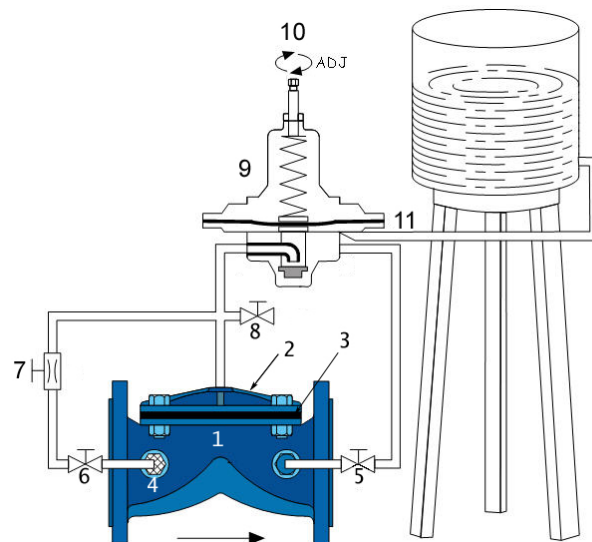

OPERATING INSTRUCTIONS

1. Connect the 1/4" port 11 of the altitude pilot to the bottom of the water tank as illustrated using 3/8" copper or Nylon tubing. It is recommended to install an isolation valve at that port for ease of future service.
2. Close needle valve 7 all the way and then reopen it for 1-2 turns. The needle valve adjusts the hydraulic reaction speed. The more the needle valve is opened the quicker the reaction is. While adjusting the needle valve, please keep in mind that opening too much will impair the valve ability to open fully due to pressure buildup between the RAF control chamber and the pilot vent port.
3. Now open the Raf completely (close the 2-way valves 5 & 6; open 2-way valve 8 and turn on the water supply to the valve) and manually fill the tank to about 1/2 meter below the desired top water level.
4. Once achieved, open valve 6 & 5 and close valve 8.
5. Loosen security nut on altitude adjusting screw 10 and turn slowly counterclockwise until the Raf closes.
6. Slowly turn altitude adjusting screw 1/2" a turn clockwise and wait a few seconds for the Raf to open. Repeat until the top water level is reached and the Raf ended automatically.
7. Make sure that there is a flow demand from the tank and allow the water level to drop about 1 meter. By now the Raf should open to fill up the water automatically. Repeat several times and fine tune to the desired level. **To increase water level, turn the adjusting screw clockwise. To decrease- counterclockwise.**

MAINTENANCE

- No maintenance is required.
- Check water level. Adjust if required.
- It is recommended that the valve be easily accessible as well as clearly marked to prevent damage.
- In freezing climates, the valve should be dismantled, and water drained during the winter months or heat protected properly

TROUBLESHOOTING RAF 40

PROBLEM	CAUSE	CHECK	SOLUTION
RAF does not open.	<ol style="list-style-type: none"> Valve 5 is turned off Blocked water connections. The minimal pressure for RAF opening is too low. The altitude pilot is out of adjustment. 	<ol style="list-style-type: none"> Check state of valve. Check the minimal opening pressure per valve size in the RAF catalogue. Repeat step 3 in operating instructions and verify "manual" opening. 	<ol style="list-style-type: none"> Open valve 5. Turn off water supply to the valve. Dismantle and clean all connections including valve's cover inlet, pilot drains and connecting tub between port 11 & tank. Reassemble and activate. Increase pressure as necessary or consult Raphael for a different control valve that will open at lower pressure. Adjust, repeating steps 2-7.
RAF does not close.	<ol style="list-style-type: none"> Valve 8 is open. Or valve 6 is closed. The altitude pilot is out of adjustment. Blocked water connections. Altitude pilot is stuck open. Foreign object on the sealing seat. Blocked self-flushing filter. 	<ol style="list-style-type: none"> Check state of valves. Close valve 5 and make sure the Raf closes properly. Constant small water flow downstream Raf takes very long to close. 	<ol style="list-style-type: none"> Close valve 8. Open valve 6. Adjust, repeating steps 2-7. Turn off water supply to the valve. Dismantle and clean all connections including valve's cover inlet, pilot drains and connecting tub between port 11 & tank. Reassemble and activate. Turn off water supply to the Raf. Dismantle and clean drain connections in pilot. Check that membrane and lower seal are not damaged. Reassemble and activate. Turn off water supply to the Raf. Remove cover and take away foreign object. Check that diaphragm body and cover are not damaged. Reassemble and activate. Turn off water supply to the Raf. Remove filter. Clean and replace if needed. Clean water connections, reassemble and activate.