



IOM RAF 63-00

Pressure Reducing Valve N.C.
3-Way Pilot & Hydraulic Relay (Galit)
2" – 4"



Jan-24

DESCRIPTION

This pressure reducing valve is an automatic NC (Normally Closed) hydraulically remote controlled valve designed to reduce a higher upstream pressure into a preset lower downstream pressure and to maintain this pressure constantly regardless of flow-rate or upstream pressure fluctuations. "Normally" means the state of the valve when the hydraulic relay isn't activated.

INSTALLATION

- Before installing the valve, flush the pipeline to remove scale, dirt and other particles that might affect the valve's performance.
- Install the valve as indicated by the arrow on the valve's cover, showing flow direction.
- Make sure that the hydraulic relay is connected to the control's pressure source.
- It is recommended to install isolation valves (butterfly valves type B8) upstream and downstream the control valve.
- Turn the 3-way selector # 6 to the "Close" position and turn on the water supply to the valve.
- Check for leaks; tighten bolts & fittings if necessary.

PARTS LIST

1. Body
2. Cover
3. Diaphragm
4. Self Flushing "Finger" Filter
5. Hydraulic relay (Galit)
6. 3-Way Pilot Model PC
7. Pressure Adjusting Screw

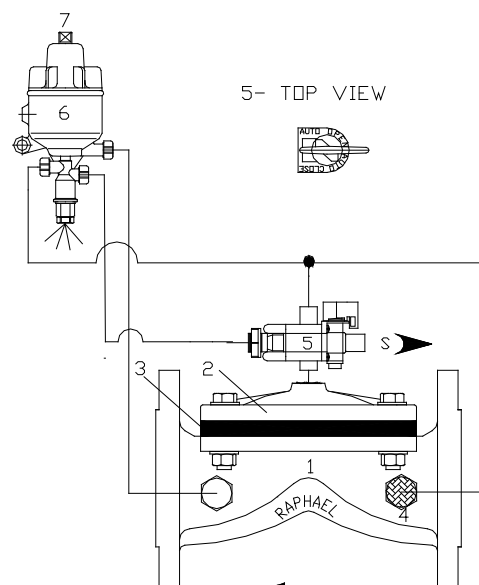

OPERATING INSTRUCTIONS

1. Make sure that there is a downstream flow demand.
2. Turn adjusting screw # 8 clockwise all the way.
3. Turn the 3-way selector # 6 to the "Auto" position.
4. Pressurize hydraulic relay # 5.
5. Turn adjusting screw # 8 counterclockwise, until water will be discharged from the bottom of pilot # 7 and the valve will start to open.
6. To increase downstream pressure, continue to turn adjusting screw # 8 counterclockwise one (1) turn at a time, allowing some time between turns for the valve to respond. Check downstream pressure until required pressure is achieved.
7. To decrease downstream pressure, turn adjusting screw # 8 clockwise one (1) turn at a time, allowing some time between turns for the valve to respond. Check downstream pressure until required pressure is achieved.

To manually open the valve completely, turn the 3-way selector # 6 to the "Open" position.

Please note that by so doing the pressure downstream will be as high as the pressure upstream.

To manually close the valve, turn the 3-way selector # 6 to the "Close" position.

To operate the valve by the hydraulic remote control, turn the 3-way selector to the "Auto" position.

To maintain preset pressure – pressurize hydraulic relay # 5.

To close the valve - de-pressurize hydraulic relay # 5.

MAINTENANCE

- Check downstream pressure. Adjust if required.
- No maintenance is required. However, from time to time it is recommended to rotate the 3-way selector to prevent sticking by sediments. It is recommended that the valve be easily accessible as well as clearly marked to prevent damage.
- In freezing climates, the valve should be dismantled, and water drained during the winter months.

TROUBLESHOOTING RAF 63 00

PROBLEM	CAUSE	CHECK	SOLUTION
The valve does not open.	<ol style="list-style-type: none"> 1. The 3-Way selector (6) is in the Close position. 2. The hydraulic relay (5) is not pressurized. 3. Blocked or stuck relay (5). 4. Blocked pilot (7). 	<ol style="list-style-type: none"> 1. Check state of the selector. 2. Check the control pressure source and the control tubes. 3. No water from relay's drain. 4. No water coming out of the pilot's drain. 	<ol style="list-style-type: none"> 1. Turn selector to the Open or Auto position. 2. Prevent bents and open clogged tubes. 3. Turn off water supply to the valve. Dismantle and clean relay's drain. Reassemble and activate. 4. Turn off water supply to valve. Dismantle and clean drains in the pilot. Reassemble and activate.
The valve does not close.	<ol style="list-style-type: none"> 1. The 3-Way selector (6) is in the Open position. 2. Hydraulic relay is still under pressure. 3. Blocked or stuck relay (5). 4. Foreign object on sealing seat. 5. Blocked self-flushing filter (4). 	<ol style="list-style-type: none"> 1. Check state of selector. 2. Check the control pressure source. 3. Check manual closing option. 4. Poor water flow in the valve downstream. 	<ol style="list-style-type: none"> 1. Turn selector to the Auto or Close position. 2. De-pressurize the control tube. If there is still pressure in the control tube (elevation), a spring has to be installed accordingly, in the hydraulic relay. 3. Turn off water supply to the valve. Dismantle and clean drain connections of the relay. Reassemble and activate. 4. Turn off water supply to the valve. Disassemble cover, diaphragm and remove foreign object. Check that diaphragm, body and cover are not damaged. Reassemble and activate. 5. Turn off water supply to the valve. Remove filter to clean or change it. Reassemble and activate
Irregular flow.	<ol style="list-style-type: none"> 1. Blocked or damaged pilot. 	<ol style="list-style-type: none"> 1. Irregular downstream pressure. 	<ol style="list-style-type: none"> 1. Turn off water supply to the valve. Dismantle and clean pilot's drains. Check state of the membrane. In case of internal parts wear, change pilot. Reassemble and activate.