



IOM RAF 8R31

Electric Pressure Sustaining Valve

1" - 4"



 **RAPHAEL**

Apr-24

DESCRIPTION

This electrically remote controlled pressure sustaining valve is an automatic control valve designed, when electrically activated, to sustain an upstream pressure to a preset minimum and maintain this pressure constantly regardless of flow-rate or upstream pressure fluctuations.

INSTALLATION

- Before installing the RAF, flush the pipeline to remove scale, dirt and other particles that might affect the valve's performance.
- Install the RAF as indicated by the arrow on the valve's cover, showing flow direction.
- Make sure that the solenoid has the right specifications and connect it to the energy source.
- It is recommended to install isolation valves upstream and downstream the control valve.
- Turn the 3-way selector # 5 to the "Close" position and turn on the water supply to the RAF.
- Check for leaks; tighten bolts & fittings if necessary.

PARTS LIST

1. Body
2. Cover
3. Diaphragm
4. Self Flushing "Finger" Filter
5. 3-Way Selector
6. 3-Way Pressure Sustaining Pilot Model PRS
7. Pressure Adjusting Screw
8. 3-Way N.C. Solenoid valve
9. Manual Override

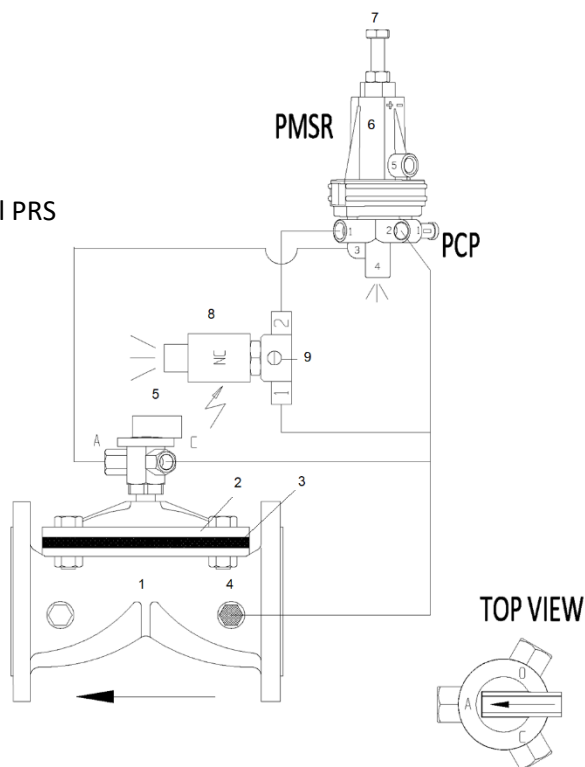

OPERATING INSTRUCTIONS

1. Make sure that there is a downstream flow demand.
2. Turn adjusting screw #7 clockwise all the way.
3. Turn the 3-way selector #5 to the "Auto" position.
4. Energize solenoid #8
5. Turn adjusting screw #7 counterclockwise, until water will start discharging from the vent port of pilot #6. The RAF will start to open.
6. To decrease minimum upstream pressure that will make the RAF open, continue to turn adjusting screw #7 counterclockwise one turn at a time, allowing some time between turns for the valve to respond. Check upstream pressure until required pressure is achieved.
7. To increase upstream pressure, turn adjusting screw #7 clockwise one turn at a time, allowing some time between turns for the valve to respond. Check upstream pressure until required pressure is achieved.

To manually open the RAF completely, turn the 3-way selector # 5 to the "Open" position. Please note that by so doing the pressure downstream will be as high as the pressure upstream.

To manually close the RAF, turn the 3-way selector # 5 to the "Close" position.

To operate the RAF electrically, turn the 3-way selector to the "Auto" position.

To remote-operate set pressure - energize solenoid # 8 or turn the manual override #9 to the "open" position (vertical).

To close the RAF - de-energize solenoid # 8.

MAINTENANCE

- Check upstream pressure. Adjust if required.
- No maintenance is required. However, from time to time it is recommended to rotate the 3-way selector 360° to prevent sticking by sediments. During the off season, energize the solenoid from time to time for the same reason.
- It is recommended that the valve will be easily accessible as well as clearly marked to prevent damage.
- In freezing climates, the RAF should be dismantled and water drained during the winter months.

TROUBLESHOOTING RAF 6R31

PROBLEM	CAUSE	CHECK	SOLUTION
The RAF does not open.	<ol style="list-style-type: none"> 1. The 3-Way selector (5) is in the "Close" position. 2. The solenoid (8) does not get electrical command. 3. The solenoid (8) gets electrical command, but the RAF does not open. Magnetic coil is damaged. 4. Blocked or stuck solenoid (8). 5. Blocked pilot valve (6). 	<ol style="list-style-type: none"> 1. Check state of the selector. 2. Check for loose contacts or faulty power supply. 3. Touch magnetic coil with a small screwdriver. It should be magnetized when energized. 4. No water from solenoid's drain. 5. No water coming out of the pilot's vent. 	<ol style="list-style-type: none"> 1. Turn selector to the "Open" or "Auto" position. 2. Reassemble and activate. 3. Replace damaged coil with a new one. Check for correct voltage. Reassemble and activate. 4. Turn off water supply to the RAF. Dismantle and clean solenoid's drain. Reassemble and activate. 5. Turn off water supply to RAF. Dismantle and clean drains in the pilot. Reassemble and activate.
The RAF does not close.	<ol style="list-style-type: none"> 1. The 3-Way selector (5) is in the "Open" position. 2. Power supply is not turned off. 3. Manual override (9) is in the "Open" position. 4. Blocked or stuck solenoid (8). 5. Foreign object on diaphragm seal (3). 6. Blocked self-flushing filter (4). 	<ol style="list-style-type: none"> 1. Check state of selector. 2. Check electrical supply to the solenoid. 3. Check position of the override. 4. Check manual closing option. 5. Poor water flow in the valve downstream. 	<ol style="list-style-type: none"> 1. Turn selector to the "Auto" or "Close" position. 2. Disconnect electrical supply. 3. Turn manual override to the "Auto" position (horizontal). 4. Turn off water supply to the RAF. Dismantle and clean solenoid's drain. Reassemble and activate. 5. Turn off water supply to the RAF. Remove cover and remove foreign object. Check that diaphragm, body and cover are not damaged. Reassemble and activate. 6. Turn off water supply to the RAF. Remove filter to clean or change it. Reassemble and activate.
Unstable pressure. RAF not maintaining set pressure upstream.	<ol style="list-style-type: none"> 1. Blocked or damaged pilot (6). 	<ol style="list-style-type: none"> 1. Irregular upstream pressure. 	<ol style="list-style-type: none"> 1. Turn off water supply to the RAF. Dismantle and clean pilot's drains. Check state of the membrane. In case of internal parts wear, change pilot. Reassemble and activate.